

## ◎ FEATURES 特性

- Can be used in a wide range of frequency to eliminate EMI/RFI
- 在较宽的频率范围内抑制和消除电磁/射频干扰
- Proportionated to meet the EIA standard, can be mounted with surface mounting equipment
- 符合EIS标准, 适用于SMT设备自动贴装
- Excellent in solderability and high heat resistance with either flow or reflow soldering.
- 可焊性和耐焊性优, 适用于流焊和再流焊。
- Accord with Q/ZHF 0031-2005 standard.
- 符合Q/ZHF 0031-2005标准

## ◎ APPLICATIONS 用途

- Noise suppression in digital equipment such as computer and its peripheral devices, VCR, VCD, DVD, camera, OA equipments, etc.
- 电脑及周边设备、VCR、VCD、DVD、照相机、办公设备等各类电子设备的数字信号的波形及接口部位的噪声控制。

## ◎ HOW TO ORDER 订货方式

CB		1608		101		T		f	
产品代号 Product code		规格尺寸 Dimensions		抗阻( $\Omega$ ) Impedance		包装方式 Packaging Style		无铅产品 Lead free Products	
CB	普通型	1608	1.6×0.8×0.8	5R0=5R		B	散包装 Bulk		
CBW	大电流	2012	2.0×1.2×0.9	101=100R			T	编带包装 Tape & Reel	
CBY	尖峰型	2012	2.0×1.2×1.2	102=1000R					
		3216	3.2×1.6×0.9						
		3216	3.2×1.6×1.1						
		3216	3.2×1.6×1.6						
		3225	3.2×2.5×1.3						
		4516	4.5×1.6×1.6						
		4532	4.5×3.2×1.5						

## ◎ DIMENSIONS 产品规格尺寸

单位: mm(inches)

Dimensions Item	L(长) Length	W(宽) Width	T(厚) Thickness	at(端头宽) Termination Width
1005 (0402)	1.0±0.15	0.5±0.15	0.5±0.15	0.25±0.15
1608 (0603)	1.6±0.15	0.8±0.15	0.8±0.15	0.3±0.2
2012 (0805)	2.0±0.2	1.2±0.2	0.85±0.1 1.2±0.2	0.4±0.2
3216 (1206)	3.2±0.2	1.6±0.2	0.85±0.1 1.1±0.2 1.6±0.2	0.5±0.3
3225 (1210)	3.2±0.2	2.5±0.2	1.3±0.3	0.5±0.3
4516 (1806)	4.5±0.2	1.6±0.2	1.6±0.3	0.5±0.3
4532 (1812)	4.5±0.2	3.2±0.2	1.5±0.3	0.5±0.3

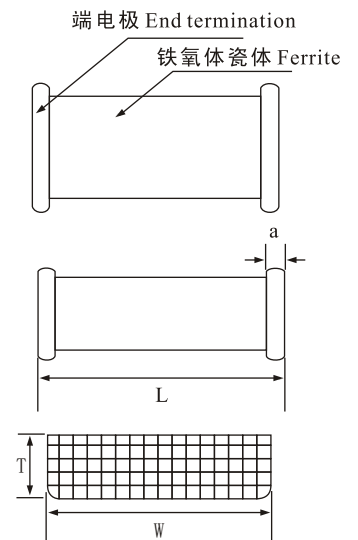

## 规格特性 SPECIFICATIONS

### CB1005 系列

型号规格 Part No.	阻抗 Impedance ( $\Omega$ ) $\pm 25\%$	测试频率 Test Frequency (MHz)	直流电阻 DC resistance ( $\Omega$ )Max	额定电流 Rated Current (mA)Max
CB1005-060	6	100	0.05	500
CB1005-110	11	100	0.05	500
CB1005-150	15	100	0.05	500
CB1005-220	22	100	0.10	300
CB1005-300	30	100	0.20	300
CB1005-470	47	100	0.30	300
CB1005-600	60	100	0.30	200
CB1005-800	80	100	0.35	200
CB1005-101	100	100	0.45	150
CB1005-121	120	100	0.45	150
CB1005-151	150	100	0.50	150
CB1005-221	220	100	0.65	100
CB1005-301	300	100	0.70	100
CB1005-331	330	100	0.80	100
CB1005-421	420	100	0.85	100
CB1005-471	470	100	1.00	50
CB1005-501	500	100	1.20	50
CB1005-601	600	100	1.20	50
CB1005-801	800	100	1.50	50
CB1005-102	1000	100	1.60	50

\*额定电流值可按客户要求

\*The Rared Current Specifaicion of Customer is welcome.

## TYPICAL ELECTRICAL CHARACTERISTICS 电气特性

**CB1005-600**

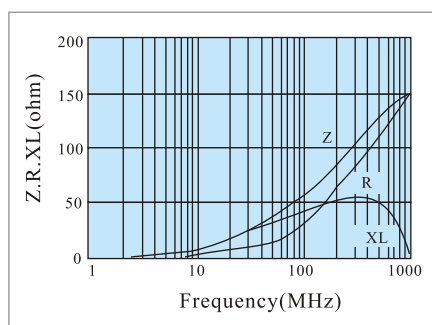

**CB1005-121**

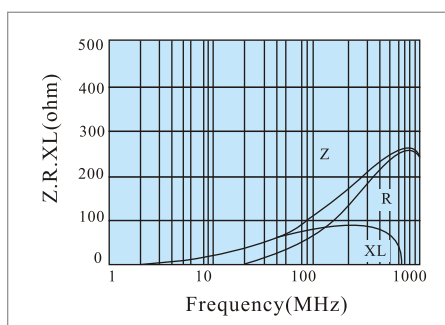

**CB1005-601**

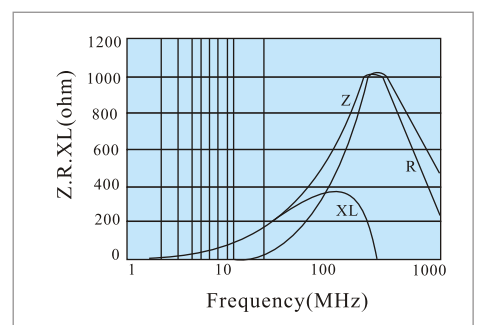

◎ 规格特性 SPECIFICATIONS

■ CB1608 系列

型号规格 Part No.	阻抗 Impedance ( $\Omega$ ) $\pm 25\%$	测试频率 Test Frequency (MHz)	直流电阻 DC resistance ( $\Omega$ )Max	额定电流 Rated Current (mA)M
CB1608-000	<10	100	0.05	800
CB1608-100	10	100	0.05	800
CB1608-110	11	100	0.05	800
CB1608-190	19	100	0.05	800
CB1608-300	30	100	0.06	800
CB1608-310	31	100	0.06	800
CB1608-330	33	100	0.10	400
CB1608-600	60	100	0.10	500
CB1608-700	70	100	0.10	500
CB1608-800	80	100	0.15	400
CB1608-101	100	100	0.20	300
CB1608-121	120	100	0.20	300
CB1608-151	150	100	0.20	300
CB1608-181	180	100	0.30	200
CB1608-221	220	100	0.40	200
CB1608-301	300	100	0.40	200
CB1608-471	470	100	0.45	200
CB1608-501	500	100	0.55	200
CB1608-601	600	100	0.50	200
CB1608-751	750	100	0.50	200
CB1608-102	1000	100	0.70	150
CB1608-122	1200	50	0.80	100
CB1608-152	1500	50	1.00	100
CB1608-182	1800	50	1.00	100
CB1608-202	2000	50	1.20	100
CB1608-222	2200	100	1.20	100

\*额定电流值可按客户要求 \*The Rared Current Specifaiaon of Customer is welcome.

◎ TYPICAL ELECTRICAL CHARACTERISTICS 电气特性

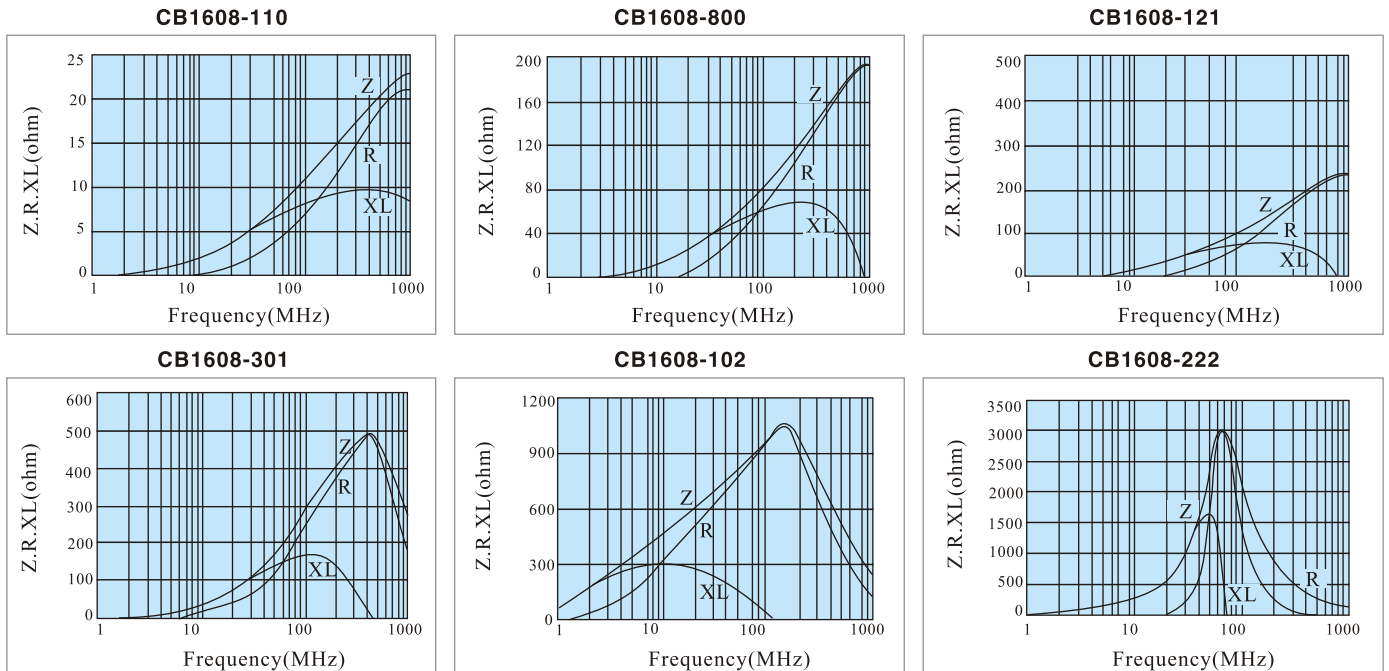

◎ 规格特性 SPECIFICATIONS

■ CB2012 系列

型号规格 Part No.	阻抗Impedance (Ω)±25%	测试频率Test Frequency (MHz)	直流电阻DC resistance (Ω)Max	额定电流Rated Current (mA)Max
CB2012-000	<10	100	0.04	1000
CB2012-100	10	100	0.04	1000
CB2012-110	11	100	0.04	1000
CB2012-190	19	100	0.04	1000
CB2012-260	26	100	0.05	1000
CB2012-300	30	100	0.10	1000
CB2012-330	33	100	0.05	1000
CB2012-360	36	100	0.06	1000
CB2012-600	60	100	0.10	1000
CB2012-700	70	100	0.10	1000
CB2012-800	80	100	0.10	1000
CB2012-121	120	100	0.15	800
CB2012-151	150	100	0.15	700
CB2012-181	180	100	0.18	700
CB2012-221	220	100	0.20	600
CB2012-301	300	100	0.20	500
CB2012-421	420	100	0.30	500
CB2012-501	500	100	0.30	500
CB2012-601	600	100	0.30	500
CB2012-751	750	100	0.35	500
CB2012-102	1000	100	0.40	500
CB2012-122	1200	50	0.45	500
CB2012-152	1500	50	0.60	300
CB2012-202	2000	50	0.80	200
CB2012-252	2500	50	0.80	200

\*额定电流值可按客户要求 \*The Rared Current Specifaion of Customer is welcome.

◎ TYPICAL ELECTRICAL CHARACTERISTICS 电气特性

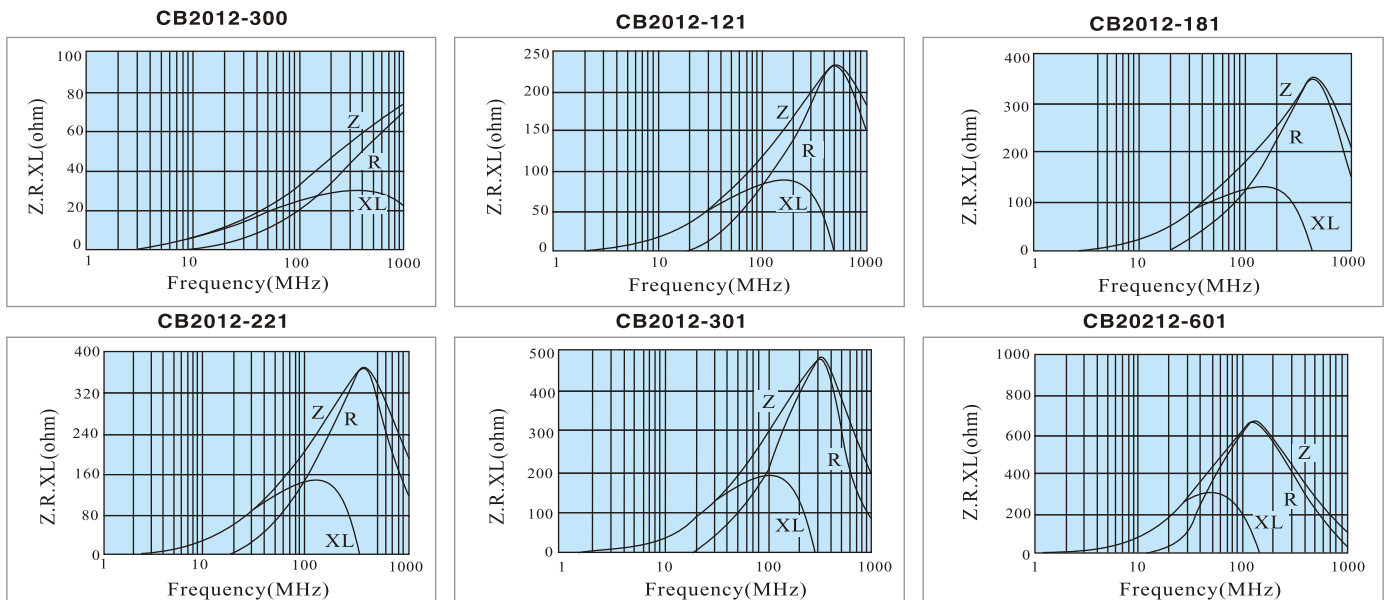



◎ 规格特性 SPECIFICATIONS

■ CB3216 系列

型号规格 Part No.	阻抗Impedance ( $\Omega$ ) $\pm$ 25%	测试频率Test Frequency (MHz)	直流电阻DC resistance ( $\Omega$ )Max	额定电流Rated Current (mA)Max
CB3216-000	<10	100	0.05	1000
CB3216-100	10	100	0.05	1000
CB3216-110	11	100	0.05	1000
CB3216-190	19	100	0.06	1000
CB3216-260	26	100	0.06	1000
CB3216-310	31	100	0.06	1000
CB3216-360	36	100	0.10	1000
CB3216-600	60	100	0.10	1000
CB3216-700	70	100	0.10	1000
CB3216-800	80	100	0.10	1000
CB3216-121	120	100	0.10	1000
CB3216-151	150	100	0.20	600
CB3216-181	180	100	0.20	600
CB3216-221	220	100	0.18	800
CB3216-301	300	100	0.20	600
CB3216-501	500	100	0.30	600
CB3216-601	600	100	0.30	600
CB3216-751	750	100	0.35	600
CB3216-102	1000	100	0.60	500
CB3216-122	1200	50	0.60	500
CB3216-152	1500	50	0.70	200
CB3216-202	2000	50	0.70	200
CB3216-252	2500	50	0.80	200
CB3216-302	3000	50	0.80	100

\*额定电流值可按客户要求 \*The Rated Current Specification of Customer is welcome.

◎ TYPICAL ELECTRICAL CHARACTERISTICS 电气特性

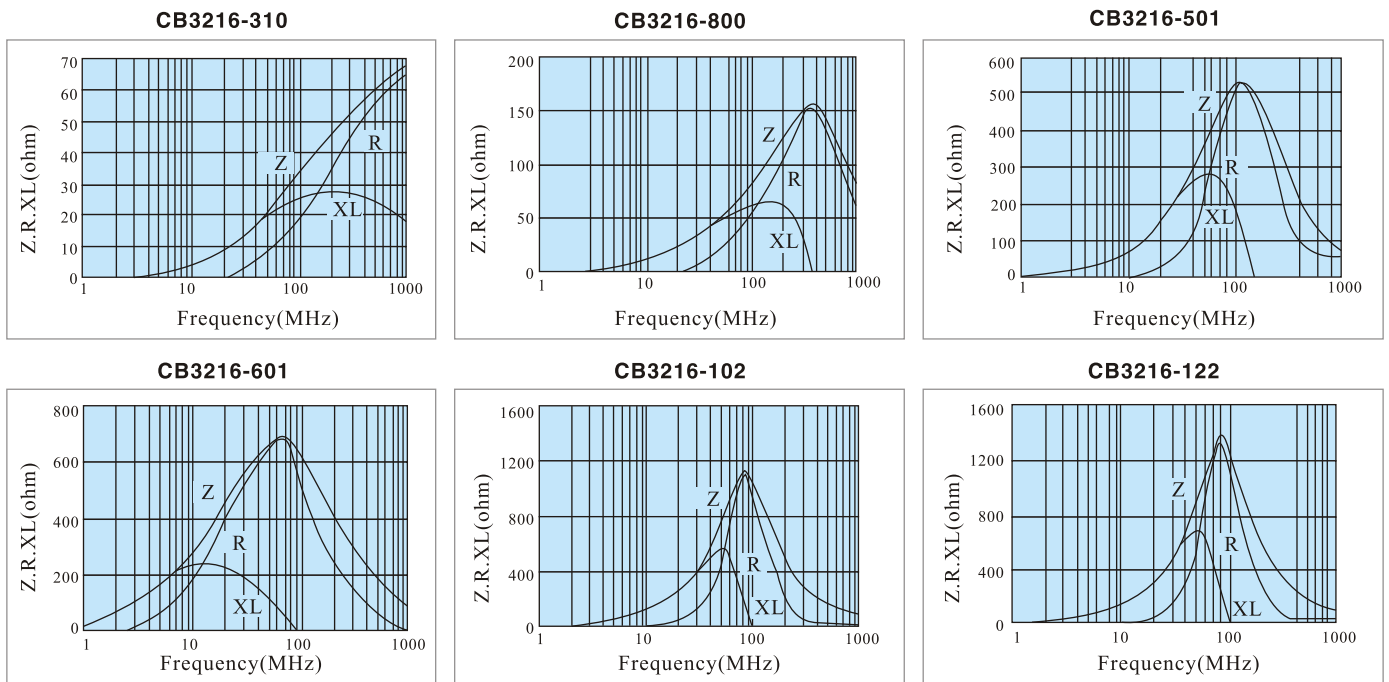

◎ 规格特性 SPECIFICATIONS

■ CB3225 系列

型号规格 Part No.	阻抗 Impedance ( $\Omega$ ) $\pm$ 25%	测试频率 Test Frequency (MHz)	直流电阻 DC resistance ( $\Omega$ )Max	额定电流 Rated Current (mA)Max
CB3225-310	31	100	0.05	1000
CB3225-500	50	100	0.05	1000
CB3225-600	60	100	0.05	1000
CB3225-700	70	100	0.05	1000
CB3225-800	80	100	0.05	1000
CB3225-900	90	100	0.10	1000
CB3225-101	100	100	0.10	1000

■ CB4516 系列

型号规格 Part No.	阻抗 Impedance ( $\Omega$ ) $\pm$ 25%	测试频率 Test Frequency (MHz)	直流电阻 DC resistance ( $\Omega$ )Max	额定电流 Rated Current (mA)Max
CB4516-300	30	100	0.05	1000
CB4516-500	50	100	0.05	1000
CB4516-600	60	100	0.05	1000
CB4516-700	70	100	0.05	1000
CB4516-800	80	100	0.05	1000
CB4516-900	90	100	0.10	1000
CB4516-101	100	100	0.10	1000
CB4516-151	150	100	0.15	1000

■ CB4532 系列

型号规格 Part No.	阻抗 Impedance ( $\Omega$ ) $\pm$ 25%	测试频率 Test Frequency (MHz)	直流电阻 DC resistance ( $\Omega$ )Max	额定电流 Rated Current (mA)Max
CB4532-300	30	100	0.05	1000
CB4532-500	50	100	0.05	1000
CB4532-600	60	100	0.05	1000
CB4532-700	70	100	0.05	1000
CB4532-800	80	100	0.05	1000
CB4532-101	100	100	0.10	1000
CB4532-121	120	100	0.10	1000
CB4532-151	150	100	0.15	1000
CB4532-221	220	100	0.20	800
CB4532-301	300	100	0.25	800
CB4532-401	400	100	0.25	800

\*额定电流值可按客户要求

\*The Rated Current Specification of Customer is welcome.

◎ 电气特性  
TYPICAL ELECTRICAL CHARACTERISTICS

**CB3225-600**

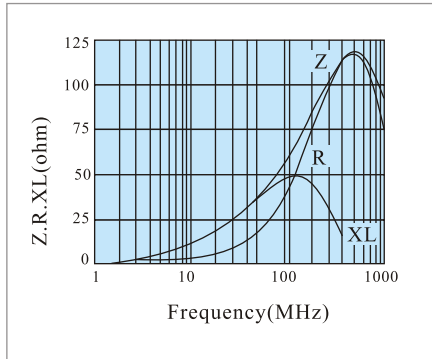

**CB4516-700**

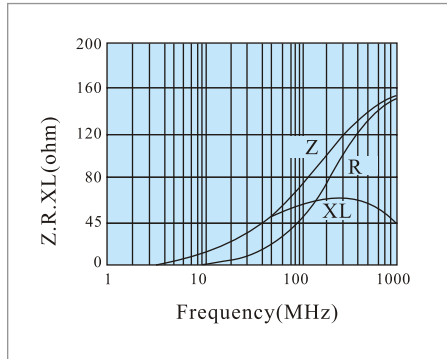

**CB4532-600**

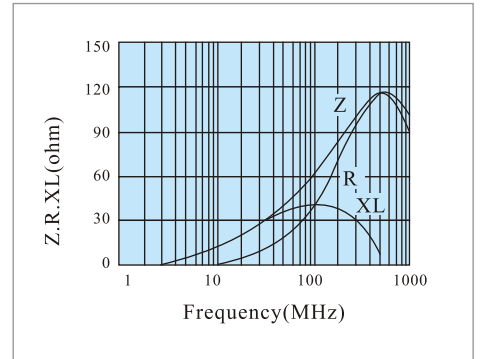

**CB3225-300**

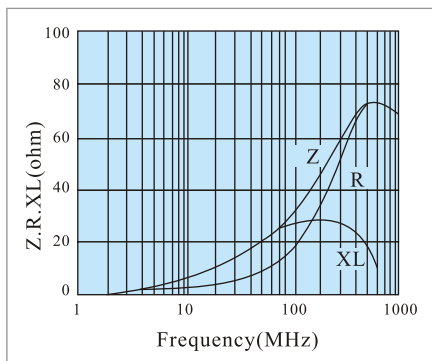

**CB3225-500**

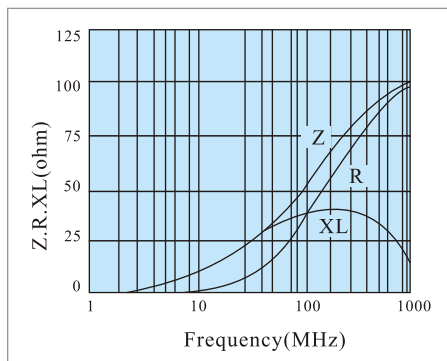

**CB4516-800**

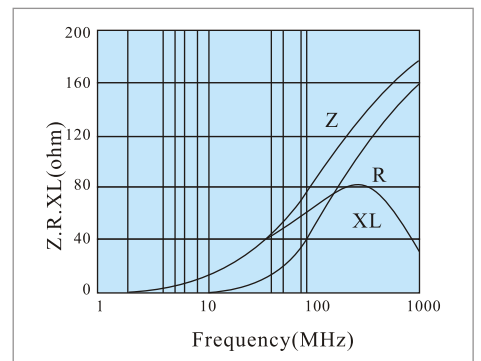

**CB4516-151**

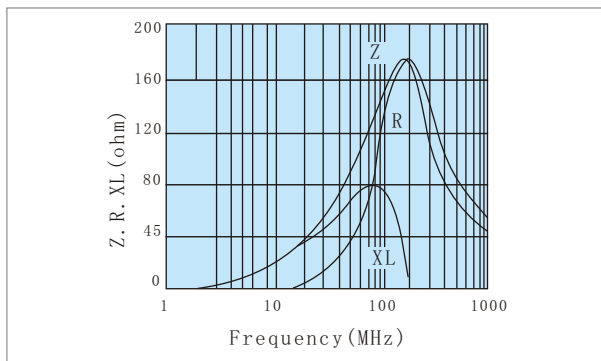

**CB4532-800**

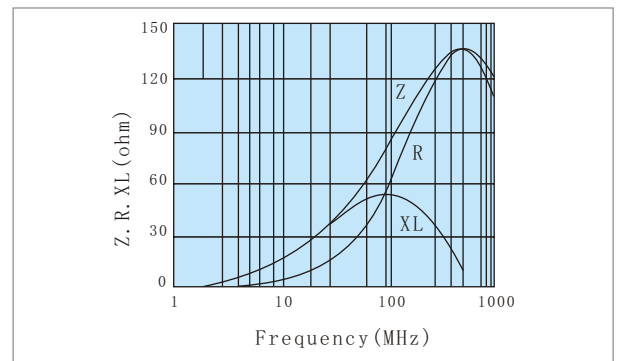

**CB4532-151**

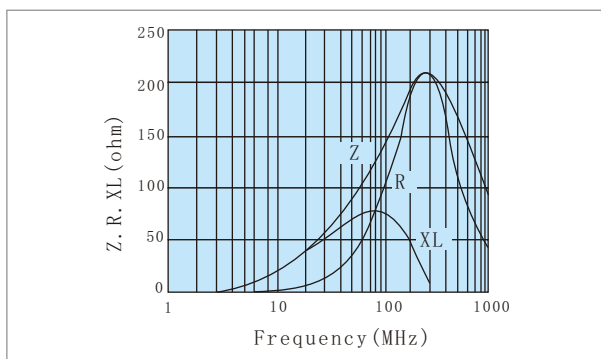

**CB4532-121**

