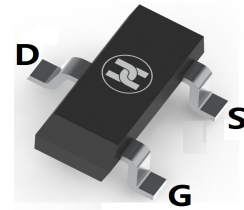
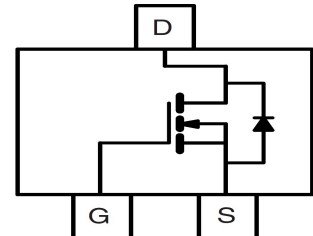

**LOW VOLTAGE MOSFET (N-CHANNEL)**
**FEATURES**

- Ultra low on-resistance:  $V_{DS}=30V, R_{DS(ON)} \leq 50m\Omega @ V_{GS}=10V, I_D=3.6A$
- For PWM application
- For Load switch application
- Surface Mount device

**SOT-23**

**MECHANICAL DATA**

- Case: SOT-23
- Case Material: Molded Plastic. UL flammability
- Classification Rating: 94V-0
- Weight: 0.008 grams (approximate)

**MAXIMUM RATINGS ( $T_A = 25^\circ C$  unless otherwise noted)**

Parameter	Symbol	Value	Unit	
Drain-source voltage	$V_{DS}$	30	V	
Gate-source voltage	$V_{GS}$	$\pm 20$	V	
Continuous drain current	$T_A=25^\circ C$	$I_D$	3.6	A
	$T_A=70^\circ C$	$I_D$	2.9	A
Pulsed drain current	$I_{DM}^*$	15	A	
Power dissipation	$T_A=25^\circ C$	$P_D$	1.40	W
	$T_A=70^\circ C$	$P_D$	0.9	W
Thermal resistance from Junction to ambient	$R_{\theta JA}$	125	$^\circ C/W$	
Junction temperature	$T_J$	150	$^\circ C$	
Storage temperature	$T_{STG}$	-55 ~ +150	$^\circ C$	

**ELECTRICAL CHARACTERISTICS ( $T_A = 25^\circ C$  unless otherwise specified)**

Parameter	Symbol	Min	Typ	Max	Unit	Conditions
Drain-Source breakdown voltage	$V_{(BR)DSS}^*$	30			V	$V_{GS}=0V, I_D=250\mu A$
Zero gate voltage drain current	$I_{DSS}^*$			1	$\mu A$	$V_{DS}=30V, V_{GS}=0V$
Gate-body leakage current	$I_{GSS}^*$			$\pm 100$	nA	$V_{DS}=0V, V_{GS}=\pm 20V$
Gate-threshold voltage	$V_{GS(th)}^*$	1.5	2	2.5	V	$V_{DS}=V_{GS}, I_D=250\mu A$
Drain-source on-resistance)	$R_{DS(ON)}^*$		36	50	m $\Omega$	$V_{GS}=10V, I_D=3.6A$
			57	80	m $\Omega$	$V_{GS}=10V, I_D=3.6A, T_J=125^\circ C$
			48	70	m $\Omega$	$V_{GS}=4.5V, I_D=2.8A$
On-State Drain Current	$I_{D(ON)}^*$	15			A	$V_{DS}=5V, V_{GS}=10V$
Forward transconductance	$g_{FS}$		11		S	$V_{DS}=5V, I_D=3.6A$
Gate resistance	$R_g$	1.7	3.5	5.3	$\Omega$	$V_{GS}=0V, V_{DS}=0V, f=1MHz$
Input capacitance	$C_{iss}$		170	210	pF	$V_{DS}=15V, V_{GS}=0V, f=1MHz$
Output capacitance	$C_{oss}$		35		pF	
Reverse transfer capacitance	$C_{rss}$		23		pF	
Turn-on delay time	$t_{d(on)}$		4.5		nS	$V_{DS}=15V, V_{GS}=10V, R_{GEN}=3\Omega, R_L=2.2\Omega$
Turn-on rise time	$t_r$		1.5		nS	
Turn-off delay time	$t_{d(off)}$		18.5		nS	
Turn-off fall time	$t_f$		15.5		nS	
Total gate charge	$Q_g$		4.05	5	nC	$V_{DS}=15V, V_{GS}=10V, I_D=3.6A$
Gate-source charge	$Q_{gs}$		0.55		nC	
Gate-drain charge	$Q_{gd}$		1		nC	
Diode forward voltage	$V_{SD}$		0.79	1	V	$I_S=1A, V_{GS}=0V$
Diode forward current	$I_S$			1.5	A	
Body Diode Reverse Recovery Time	$t_{rr}$		7.5	10	nS	$I_F=3.6A, dI/dt=100A/\mu s$
Body Diode Reverse Recovery Charge	$Q_{rr}$		2.5		nC	$I_F=3.6A, dI/dt=100A/\mu s$

\*Pulse test ; Pulse width  $\leq 300\mu s$ , Duty cycle  $\leq 0.5\%$  .

LOW VOLTAGE MOSFET (N-CHANNEL)

Typical Characteristics

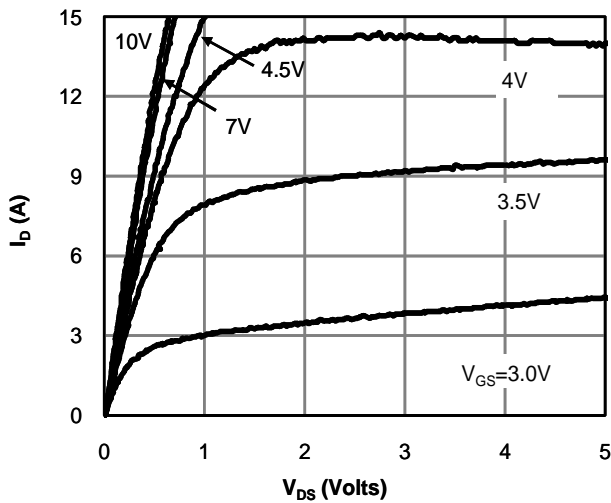

Fig 1: On-Region Characteristics

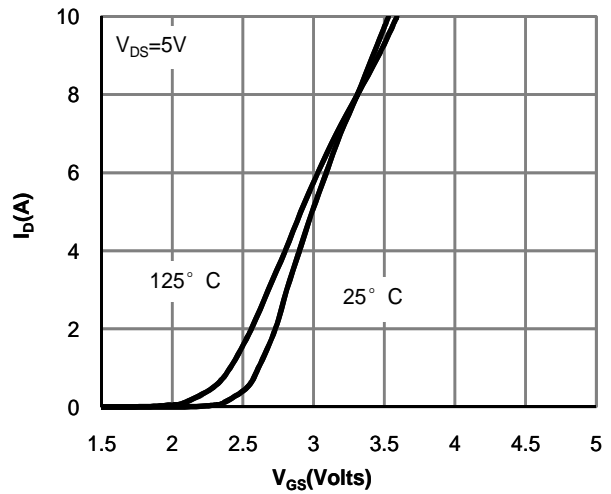

Figure 2: Transfer Characteristics

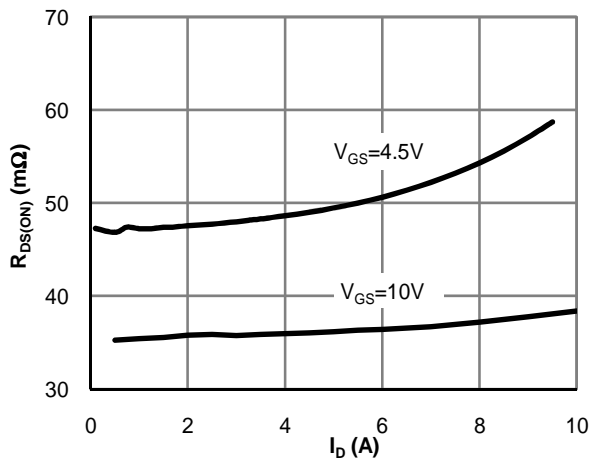

Figure 3: On-Resistance vs. Drain Current and Gate Voltage

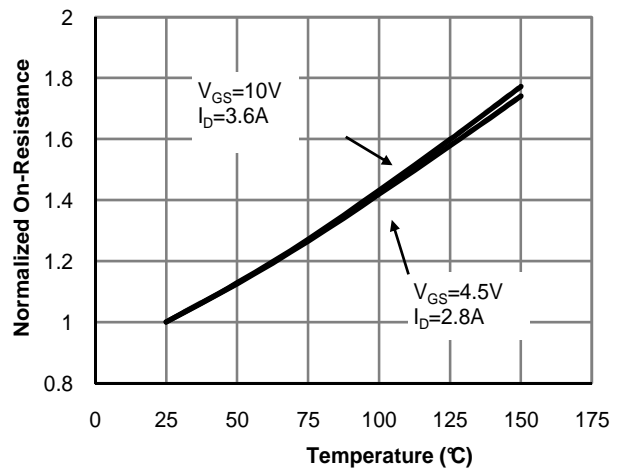

Figure 4: On-Resistance vs. Junction Temperature

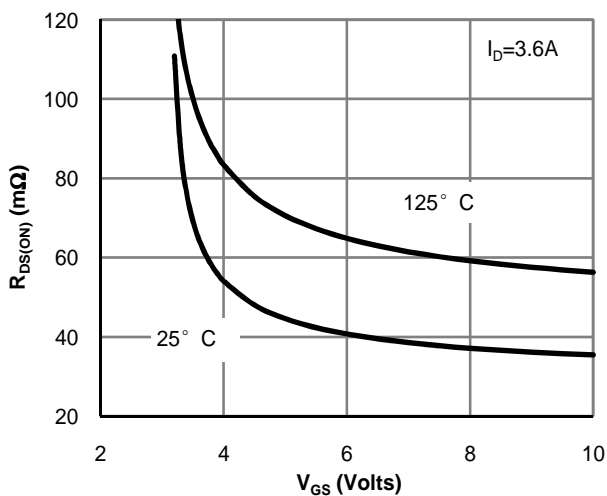

Figure 5: On-Resistance vs. Gate-Source Voltage

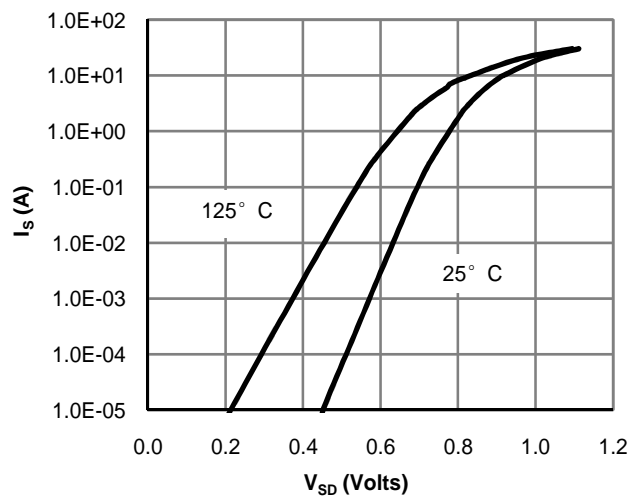

Figure 6: Body-Diode Characteristics

LOW VOLTAGE MOSFET (N-CHANNEL)

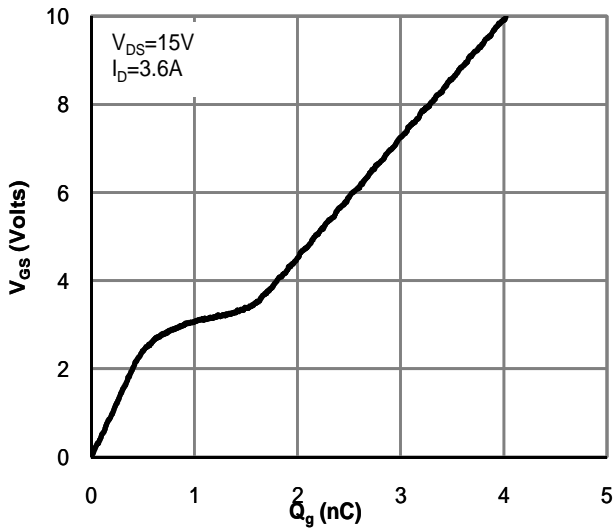

Figure 7: Gate-Charge Characteristics

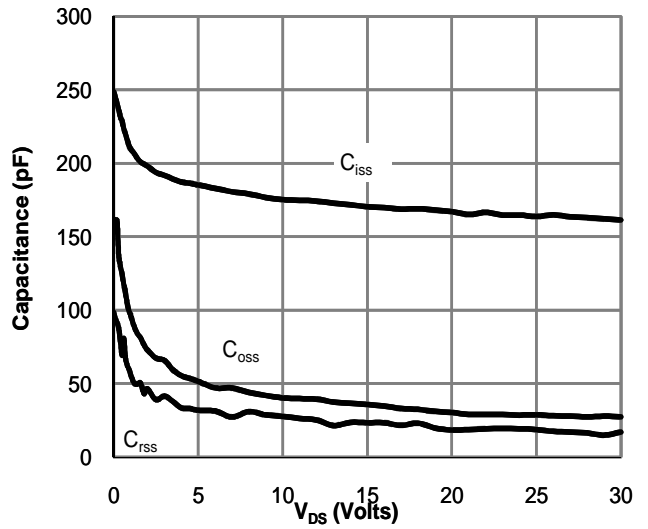

Figure 8: Capacitance Characteristics

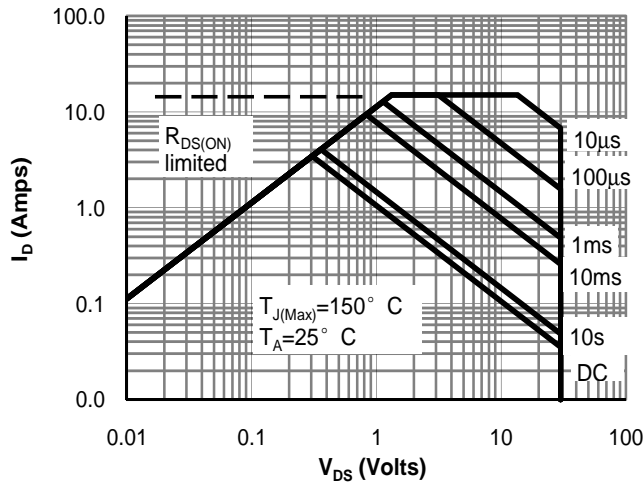

Figure 9: Maximum Forward Biased Safe Operating Area

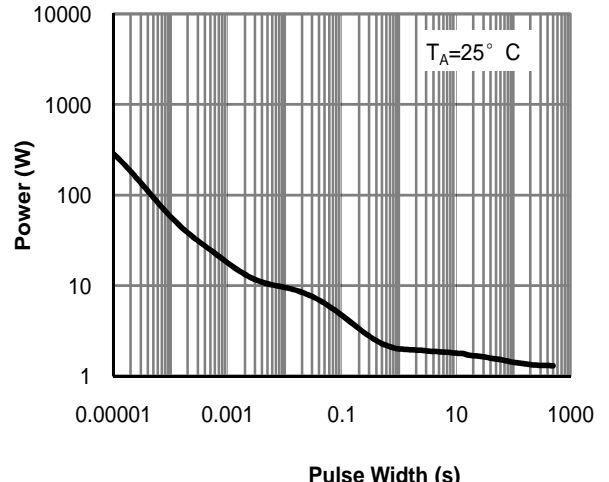

Figure 10: Single Pulse Power Rating Junction-to-Ambient

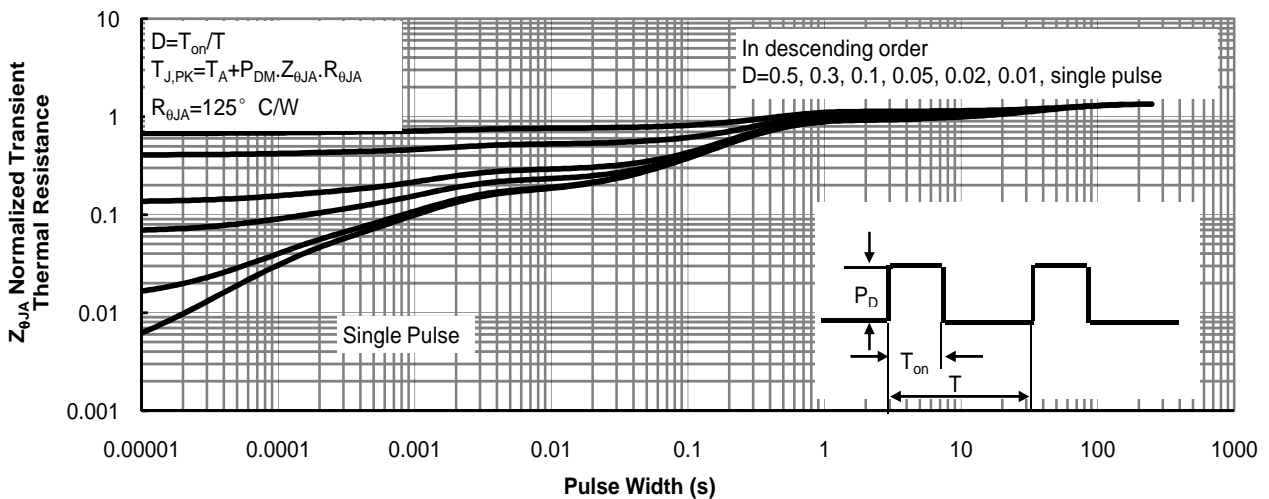
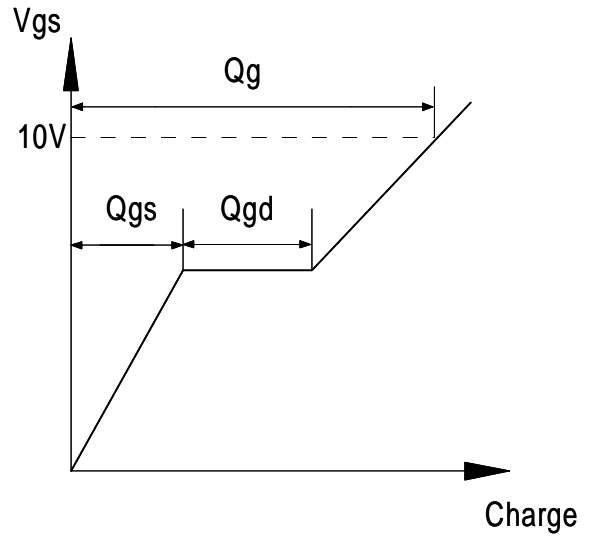
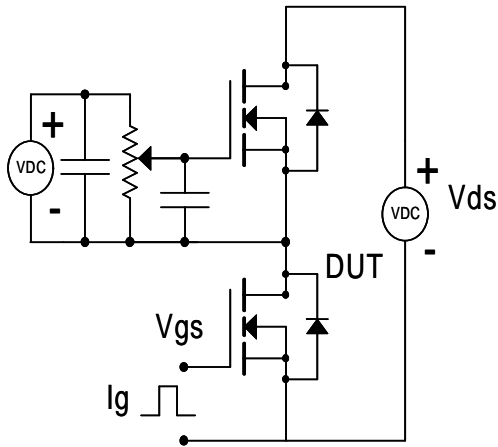

Figure 11: Normalized Maximum Transient Thermal Impedance

LOW VOLTAGE MOSFET (N-CHANNEL)

Gate Charge Test Circuit & Waveform



Resistive Switching Test Circuit & Waveforms

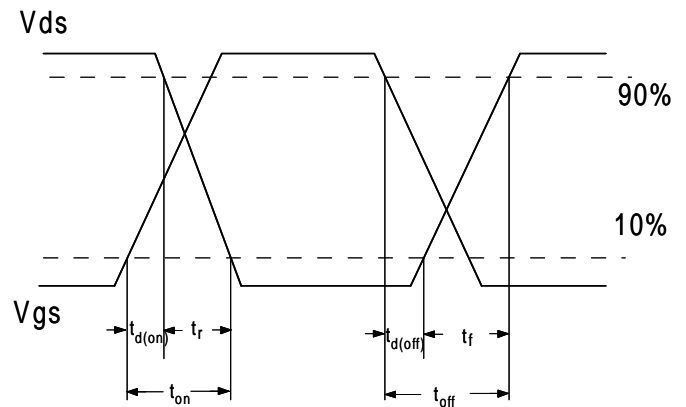
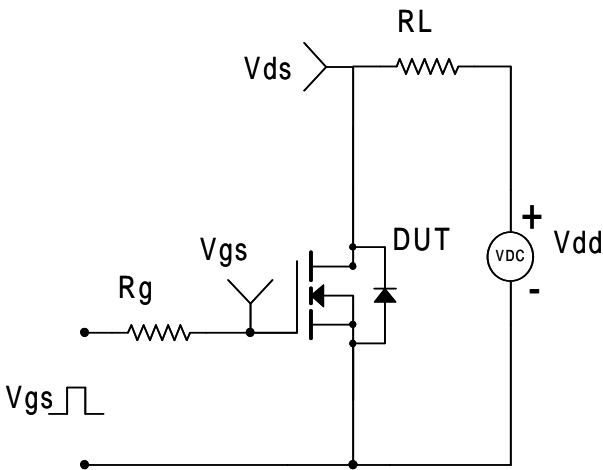

Diode Recovery Test Circuit & Waveforms

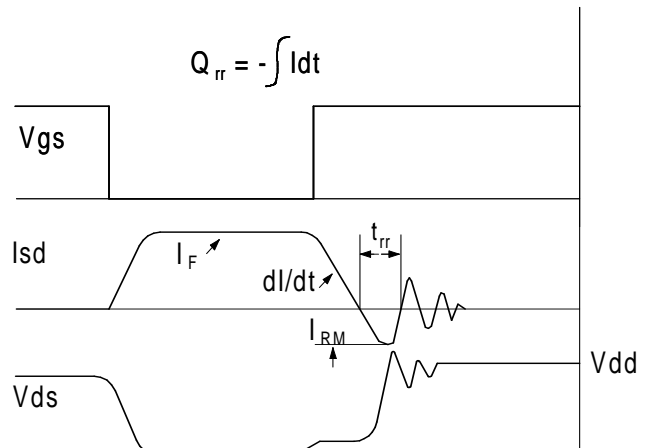
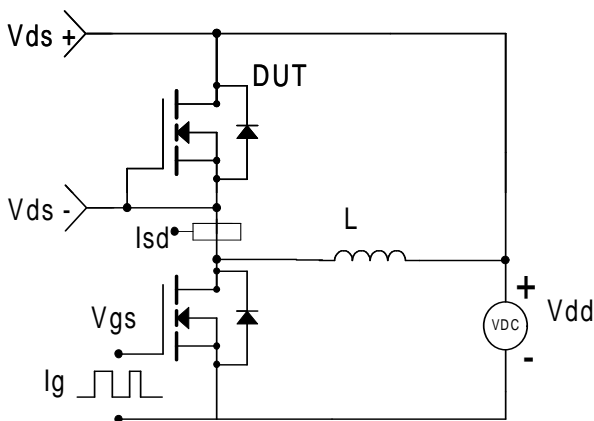

LOW VOLTAGE MOSFET (N-CHANNEL)

SOT-23 Package Outline Dimensions

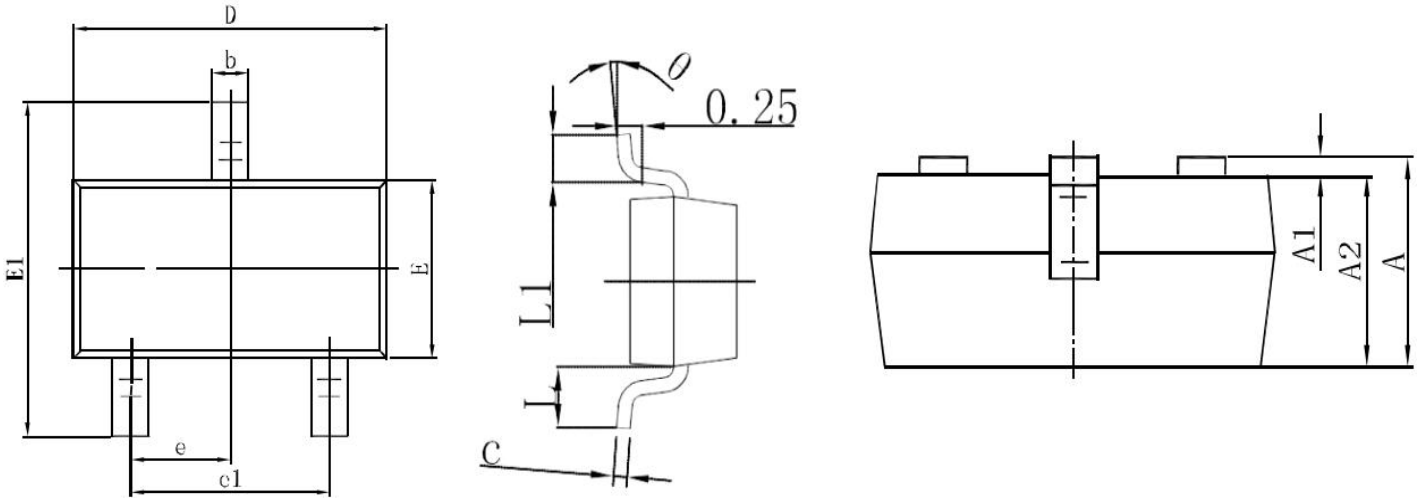

Symbol	Dimensions In Millimeters		Dimensions In Inches	
	Min	Max	Min	Max
A	0.900	1.150	0.354	0.453
A1	0.000	0.100	0.000	0.039
A2	0.900	1.050	0.354	0.413
b	0.300	0.500	0.118	0.197
c	0.080	1.150	0.031	0.453
D	2.900	3.100	1.142	1.220
E	1.200	1.400	0.472	0.551
E1	2.250	2.550	0.886	1.004
e	0.95REF		0.374REF	
e1	1.800	2.000	0.709	0.787
L	0.55REF		0.215REF	
L1	0.300	0.500	0.118	0.197

SOT-23 Suggested Pad Layout

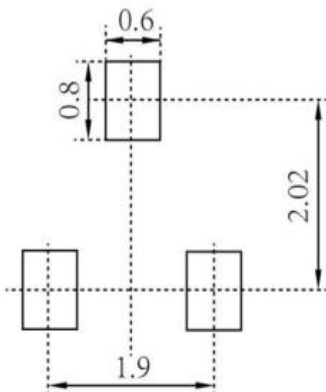

Note:

1. Controlling dimension: in millimeters
2. General tolerance:  $\pm 0.05\text{mm}$
3. The pad layout is for reference purposes only

LOW VOLTAGE MOSFET (N-CHANNEL)

**SOT-23 Tape and Reel**

**SOT-23 Embossed Carrier Tape**

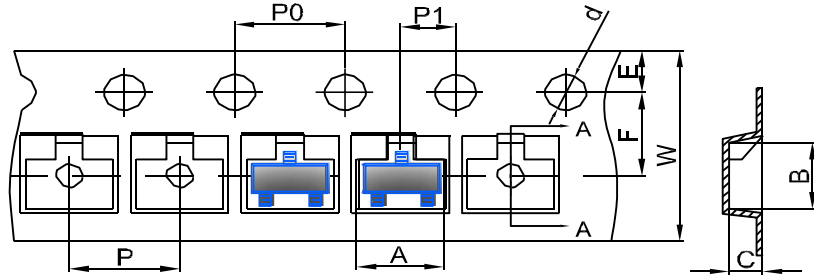

DIMENSIONS ARE IN MILLIMETER										
TYPE	A	B	C	d	E	F	P0	P	P1	W
SOT-23	3.15	2.77	1.22	Ø1.50	1.75	3.50	4.00	4.00	2.00	8.00
TOLERANCE	±0.1	±0.1	±0.1	±0.1	±0.1	±0.1	±0.1	±0.1	±0.1	±0.1

**SOT-23 Tape Leader and Trailer**

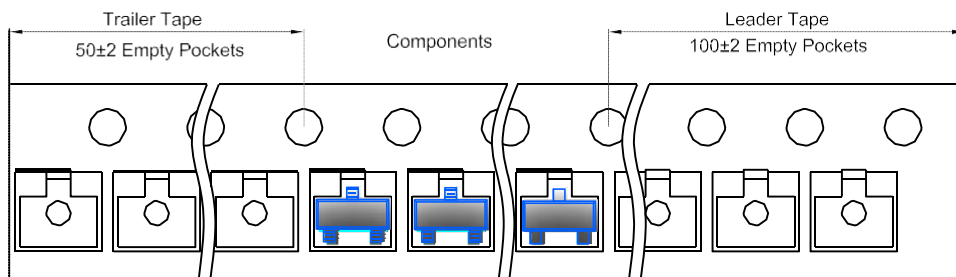

**SOT-23 Reel**

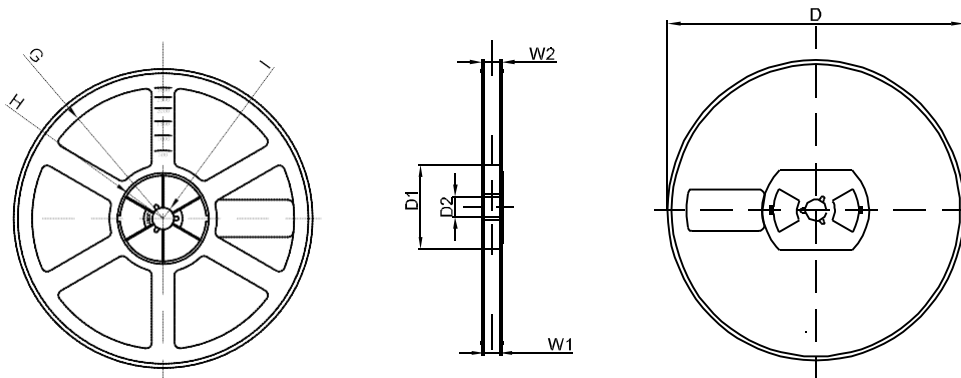

DIMENSIONS ARE IN MILLIMETER								
REEL OPTION	D	D1	D2	G	H	I	W1	W2
7" DIA	Ø178	54.40	13.00	R78	R25.60	R6.50	9.50	12.30
TOLERANCE	±2	±1	±1	±1	±1	±1	±1	±1