

LOW VOLTAGE MOSFET (N-CHANNEL)

FEATURES

- Ultra low on-resistance: $V_{DS}=30V, R_{DS(ON)} \leq 28m\Omega @ V_{GS}=10V, I_D=5.8A$
- For PWM application
- For Load switch application
- Surface Mount device

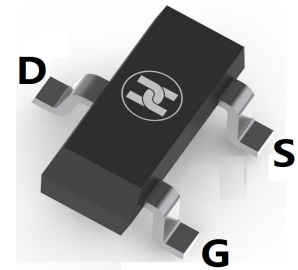

SOT-23

MECHANICAL DATA

- Case: SOT-23
- Case Material: Molded Plastic. UL flammability
- Classification Rating: 94V-0
- Weight: 0.008 grams (approximate)

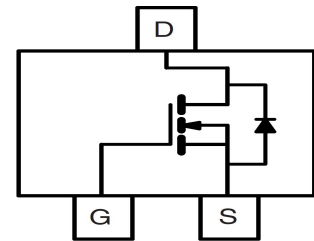

MAXIMUM RATINGS (T_A = 25°C unless otherwise noted)

Parameter	Symbol	Value	Unit	
Drain-source voltage	V _{DS}	30	V	
Gate-source voltage	V _{GS}	±12	V	
Continuous drain current	T _A =25°C	I _D	5.8	A
	T _A =70°C	I _D	4.9	A
Pulsed drain current	I _{DM} *	30	A	
Power dissipation	T _A =25°C	P _D	1.40	W
	T _A =70°C	P _D	1	W
Thermal resistance from Junction to ambient	R _{θJA}	125	°C/W	
Junction temperature	T _J	150	°C	
Storage temperature	T _{STG}	-55 ~+150	°C	

LOW VOLTAGE MOSFET (N-CHANNEL)
ELECTRICAL CHARACTERISTICS (T_A = 25°C unless otherwise specified)

Parameter	Symbol	Min	Typ	Max	Unit	Conditions
Drain-Source breakdown voltage	V _{(BR)DSS} *	30			V	V _{GS} =0V, I _D =250μA
Zero gate voltage drain current	I _{DSS} *			1	uA	V _{DS} =24V, V _{GS} =0V
Gate-body leakage current	I _{GSS} *			±100	nA	V _{DS} =0V, V _{GS} =±12V
Gate-threshold voltage	V _{GS(th)} *	0.5	0.8	1	V	V _{DS} =V _{GS} , I _D =250μA
Drain-source on-resistance)	R _{DS(ON)} *		23	28	mΩ	V _{GS} =10V, I _D =5.8A
			26	33	mΩ	V _{GS} =4.5V, I _D =5A
			35	42	mΩ	V _{GS} =2.5V, I _D =4A
			54	72	mΩ	V _{GS} =1.8V, I _D =3A
On-State Drain Current	I _{D(ON)} *	30			A	V _{DS} =5V, V _{GS} =10V
Forward transconductance	g _{FS}	12	17		S	V _{DS} =5V, I _D =5A
Gate resistance	R _g		1.3		Ω	V _{GS} =0V, V _{DS} =0V, f=1MHz
Input capacitance	C _{iss}		767		pF	V _{DS} =15V, V _{GS} =0V, f=1MHz
Output capacitance	C _{oss}		111		pF	
Reverse transfer capacitance	C _{rss}		82		pF	
Turn-on delay time	t _{d(on)}		5		nS	V _{DS} =15V, V _{GS} =10V, R _{GEN} =6Ω, R _L =2.7Ω
Turn-on rise time	t _r		5.5		nS	
Turn-off delay time	t _{d(off)}		39		nS	
Turn-off fall time	t _f		4.7		nS	
Total gate charge	Q _g		10		nC	V _{DS} =15V, V _{GS} =10V, I _D =3.6A
Gate-source charge	Q _{gs}		1.2		nC	
Gate-drain charge	Q _{gd}		3.1		nC	
Diode forward voltage	V _{SD}		0.66	1	V	I _S =1A, V _{GS} =0V
Diode forward current	I _S			2.5	A	
Body Diode Reverse Recovery Time	t _{rr}		15		nS	I _F =5A, dI/dt=100A/us
Body Diode Reverse Recovery Charge	Q _{rr}		7.1		nC	I _F =5A, dI/dt=100A/us

*Pulse test ; Pulse width ≤80μs, Duty cycle ≤ 0.5% .

LOW VOLTAGE MOSFET (N-CHANNEL)

SOT-23 Package Outline Dimensions

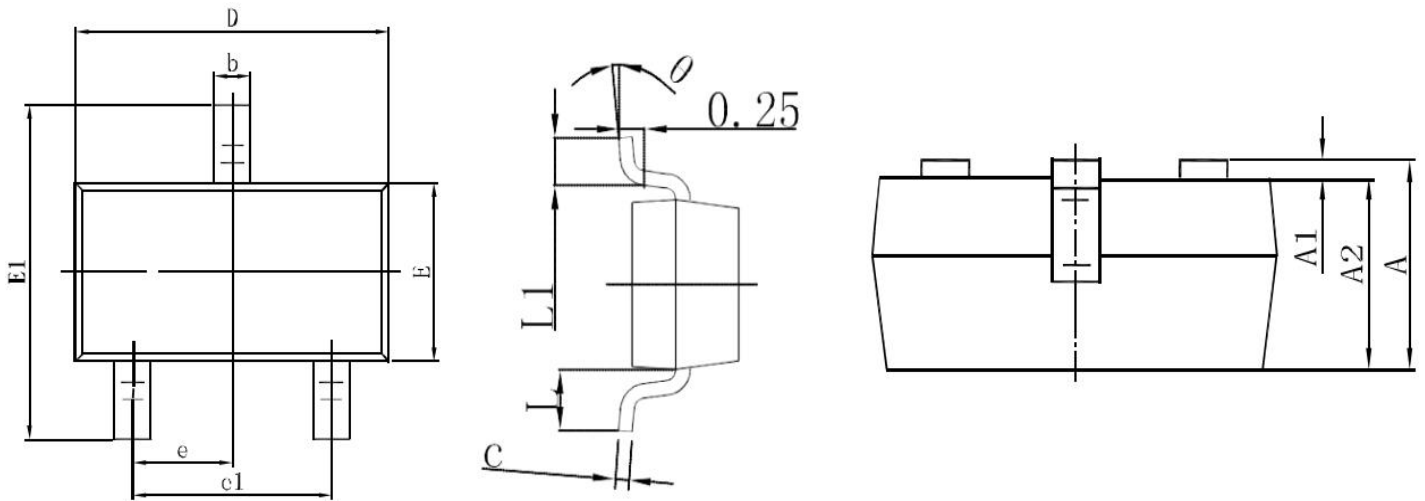

Symbol	Dimensions In Millimeters		Dimensions In Inches	
	Min	Max	Min	Max
A	0.900	1.150	0.354	0.453
A1	0.000	0.100	0.000	0.039
A2	0.900	1.050	0.354	0.413
b	0.300	0.500	0.118	0.197
c	0.080	1.150	0.031	0.453
D	2.900	3.100	1.142	1.220
E	1.200	1.400	0.472	0.551
E1	2.250	2.550	0.886	1.004
e	0.95REF		0.374REF	
e1	1.800	2.000	0.709	0.787
L	0.55REF		0.215REF	
L1	0.300	0.500	0.118	0.197

SOT-23 Suggested Pad Layout

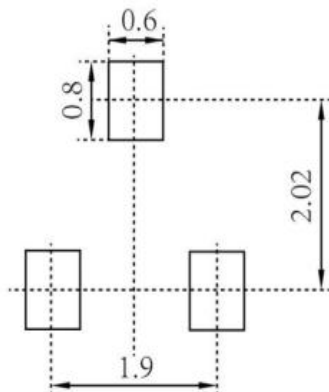

Note:

1. Controlling dimension: in millimeters
2. General tolerance: $\pm 0.05\text{mm}$
3. The pad layout is for reference purposes only

LOW VOLTAGE MOSFET (N-CHANNEL)

SOT-23 Tape and Reel

SOT-23 Embossed Carrier Tape

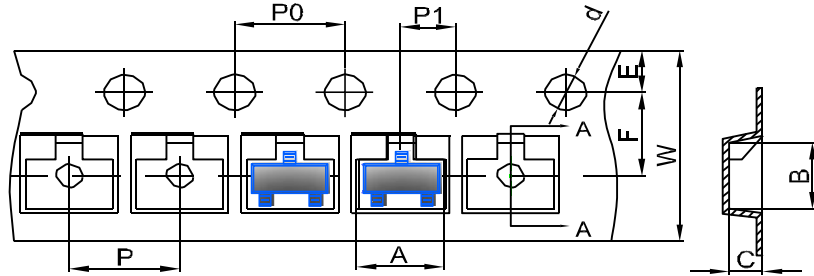

DIMENSIONS ARE IN MILLIMETER										
TYPE	A	B	C	d	E	F	P0	P	P1	W
SOT-23	3.15	2.77	1.22	Ø1.50	1.75	3.50	4.00	4.00	2.00	8.00
TOLERANCE	±0.1	±0.1	±0.1	±0.1	±0.1	±0.1	±0.1	±0.1	±0.1	±0.1

SOT-23 Tape Leader and Trailer

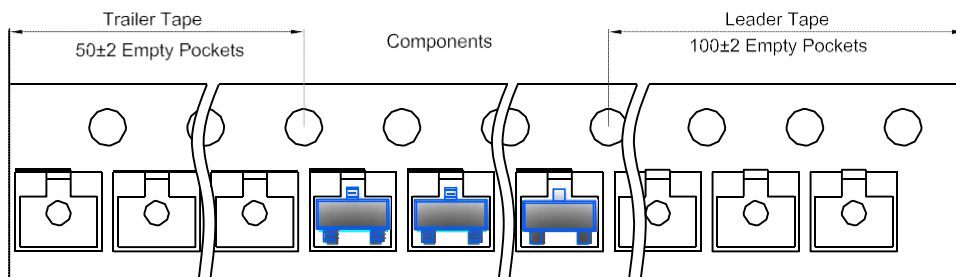

SOT-23 Reel

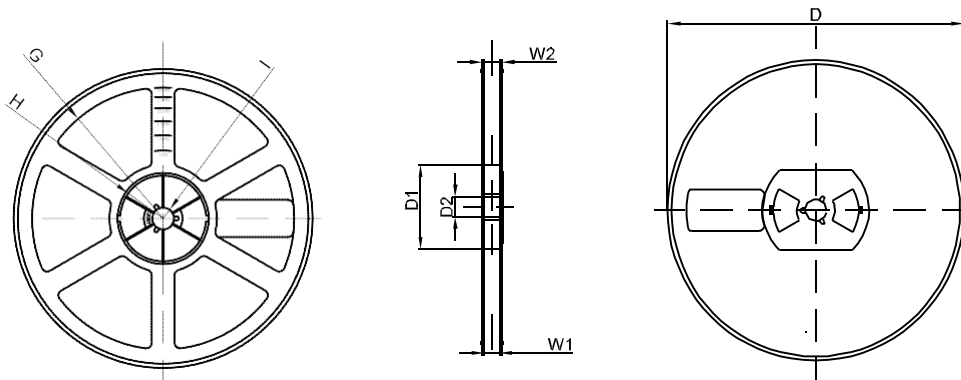

DIMENSIONS ARE IN MILLIMETER								
REEL OPTION	D	D1	D2	G	H	I	W1	W2
7" DIA	Ø178	54.40	13.00	R78	R25.60	R6.50	9.50	12.30
TOLERANCE	±2	±1	±1	±1	±1	±1	±1	±1