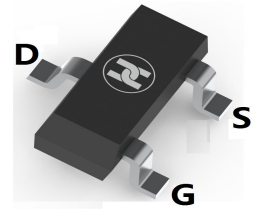
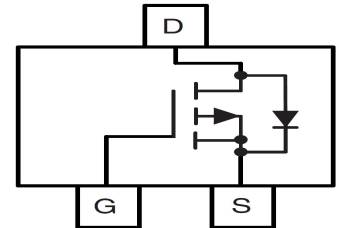

LOW VOLTAGE MOSFET (P-CHANNEL)
FEATURES

- $V_{DS}=-20V, R_{DS(ON)} \leq 70m\Omega @ V_{GS}=-4.5V, I_D=-3.5A$
- Low on-resistance and low gate charge
- For buck convertor applications
- Surface Mount device

SOT-23
MECHANICAL DATA

- Case: SOT-23
- Case Material: Molded Plastic. UL flammability
- Classification Rating: 94V-0
- Weight: 0.008 grams (approximate)

MAXIMUM RATINGS ($T_A = 25^\circ C$ unless otherwise noted)

| Parameter | Symbol | 10Sec | Steady state | Unit | |
|---|-----------------|------------------|--------------|--------------|---|
| Drain-source voltage | V_{DS} | | -20 | V | |
| Gate-source voltage | V_{GS} | | ± 8 | V | |
| Continuous drain current | I_D | $T_A=25^\circ C$ | -3.5 | -2.9 | A |
| | | $T_A=70^\circ C$ | -2.7 | -2.3 | A |
| Pulsed drain current | I_{DM} | | -25 | A | |
| Power dissipation | P_D | $T_A=25^\circ C$ | 1.4 | 1 | W |
| | | $T_A=70^\circ C$ | 0.9 | 0.6 | W |
| Thermal resistance from Junction to ambient | $R_{\theta JA}$ | | 125 | $^\circ C/W$ | |
| Junction temperature | T_J | | 150 | $^\circ C$ | |
| Storage temperature | T_{STG} | | -55~+150 | $^\circ C$ | |

ELECTRICAL CHARACTERISTICS ($T_A = 25^\circ C$ unless otherwise specified)

| Parameter | Symbol | Min | Typ | Max | Unit | Conditions |
|------------------------------------|-----------------|------|-------|-----------|------------|---|
| Drain-Source breakdown voltage | $V_{(BR)DSS}^*$ | -20 | | | V | $V_{GS}=0V, I_D=-250\mu A$ |
| Zero gate voltage drain current | I_{DSS}^* | | | -1 | μA | $V_{DS}=-20V, V_{GS}=0V$ |
| Gate-body leakage current | I_{GSS}^* | | | ± 100 | nA | $V_{DS}=0V, V_{GS}=\pm 8V$ |
| Gate-threshold voltage | $V_{GS(th)}^*$ | -0.5 | -0.65 | -1 | V | $V_{DS}=V_{GS}, I_D=-250\mu A$ |
| On state drain current | $I_{D(ON)}^*$ | -25 | | | A | $V_{GS}=-4.5V, V_{DS}=-5V$ |
| Drain-source on-resistance | $R_{DS(ON)}^*$ | | 56 | 70 | m Ω | $V_{GS}=-4.5V, I_D=-3.5A$ |
| | | | 70 | 90 | m Ω | $V_{GS}=-2.5V, I_D=-3.0A$ |
| | | | 85 | 110 | m Ω | $V_{GS}=-1.8V, I_D=-2.0A$ |
| | | | 100 | 130 | m Ω | $V_{GS}=-1.5V, I_D=-0.5A$ |
| Forward transconductance | g_{FS} | | 15 | | S | $V_{DS}=-5V, I_D=-3.5A$ |
| Gate resistance | R_g | | 18 | 23 | Ω | $V_{DS}=0V, V_{GS}=0V, f=1MHz$ |
| Input capacitance | C_{iss} | | 510 | 745 | pF | $V_{DS}=-10V, V_{GS}=0V, f=1MHz$ |
| Output capacitance | C_{oss} | | 70 | | pF | |
| Reverse transfer capacitance | C_{rss} | | 52 | | pF | |
| Turn-on delay time | $t_{d(on)}$ | | 11 | | nS | $V_{GS}=-4.5V, V_{DS}=-10V, R_{GEN}=6\Omega, R_L=3\Omega$ |
| Turn-on rise time | t_r | | 10 | | nS | |
| Turn-off delay time | $t_{d(off)}$ | | 60 | | nS | |
| Turn-off fall time | t_f | | 30 | | nS | |
| Total gate charge | Q_g | | 5.6 | 11 | nC | $V_{DS}=-10V, V_{GS}=-4.5V, I_D=-3.5A$ |
| Gate-source charge | Q_{gs} | | 0.6 | | nC | |
| Gate-drain charge | Q_{gd} | | 1.8 | | nC | |
| Diode forward voltage | V_{SD} | | -0.7 | -1 | V | $I_S=-1A, V_{GS}=0V$ |
| Diode forward current | I_S | | | -1.4 | A | |
| Body Diode Reverse Recovery Time | t_{rr} | | 17 | 49 | nS | $I_F=-3.5A, dI/dt=100A/\mu s$ |
| Body Diode Reverse Recovery Charge | Q_{rr} | | 4 | | nC | |

* Pulse test ; Pulse width $\leq 300\mu s$, Duty cycle $\leq 0.5\%$.

LOW VOLTAGE MOSFET (P-CHANNEL)

Typical Characteristics

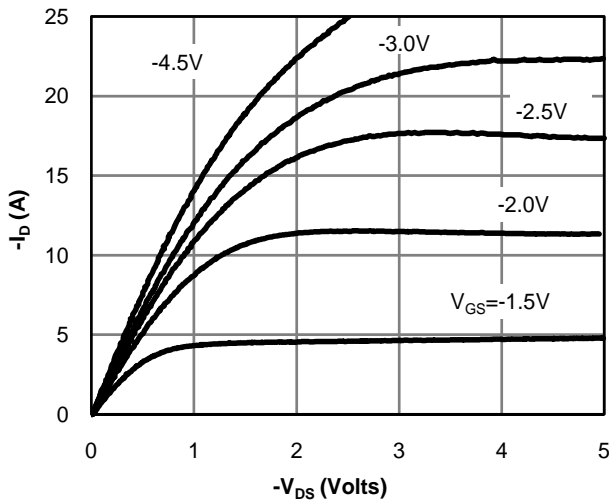

Figure 1: On-Region Characteristics

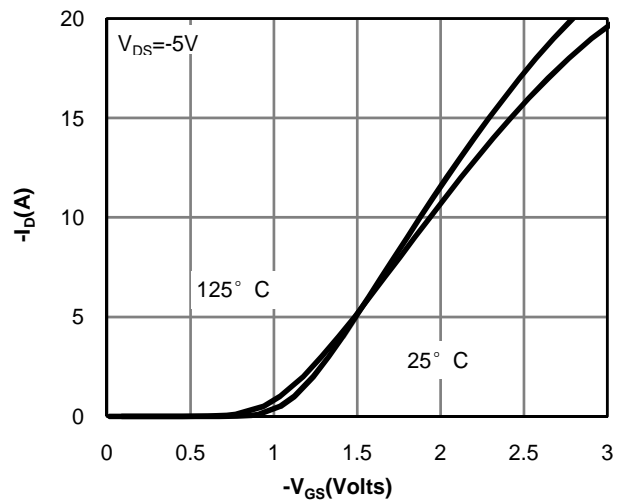

Figure 2: Transfer Characteristics

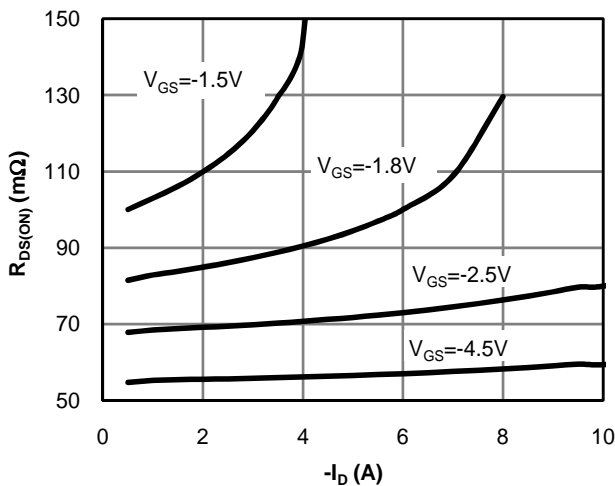

Figure 3: On-Resistance vs. Drain Current and Gate Voltage

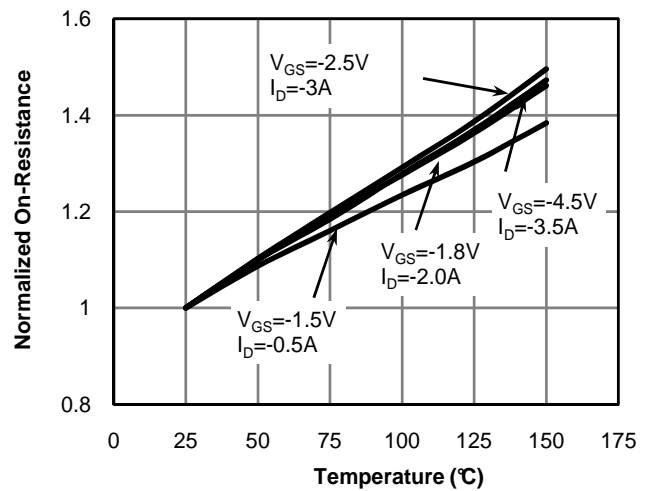

Figure 4: On-Resistance vs. Junction Temperature

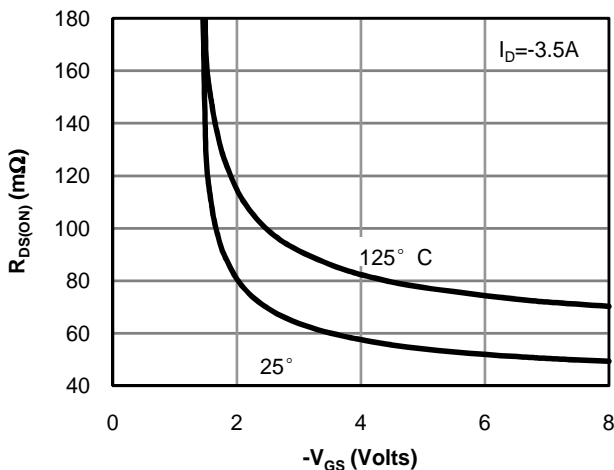

Figure 5: On-Resistance vs. Gate-Source Voltage

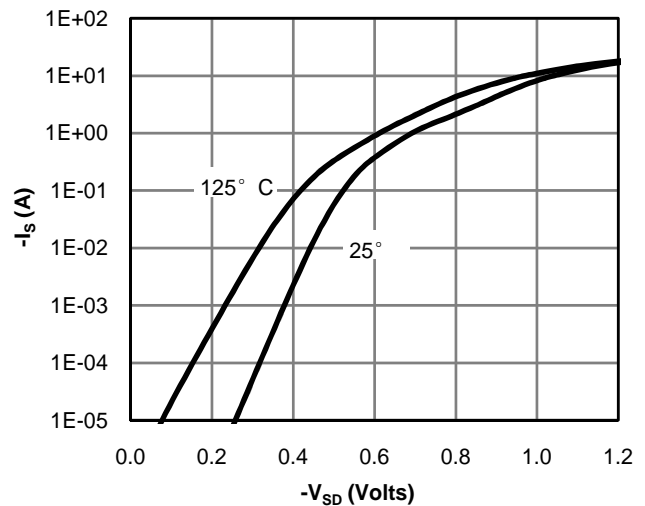

Figure 6: Body-Diode Characteristics

LOW VOLTAGE MOSFET (P-CHANNEL)

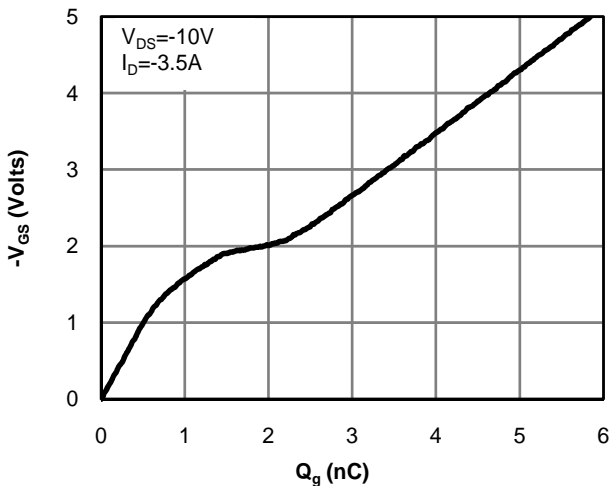

Figure 7: Gate-Charge Characteristics

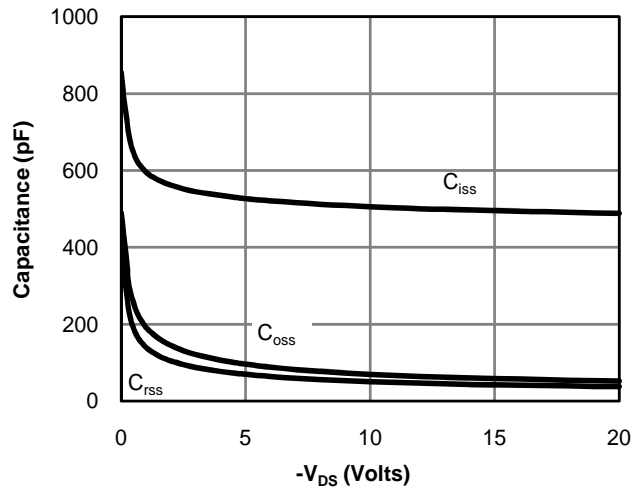

Figure 8: Capacitance Characteristics

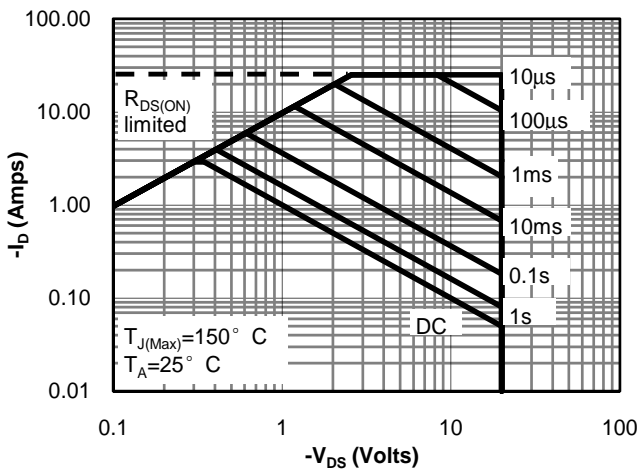

Figure 9: Maximum Forward Biased Safe Operating Area

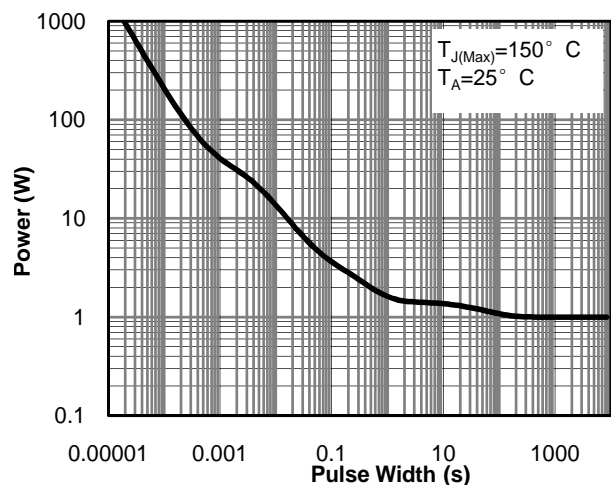

Figure 10: Single Pulse Power Rating Junction-to-Ambient

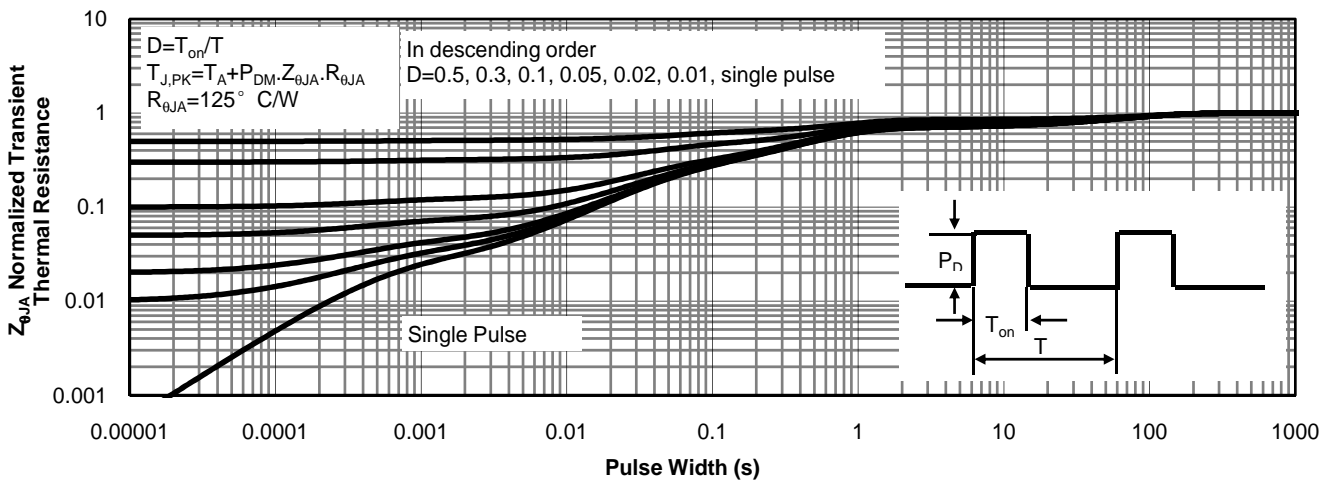
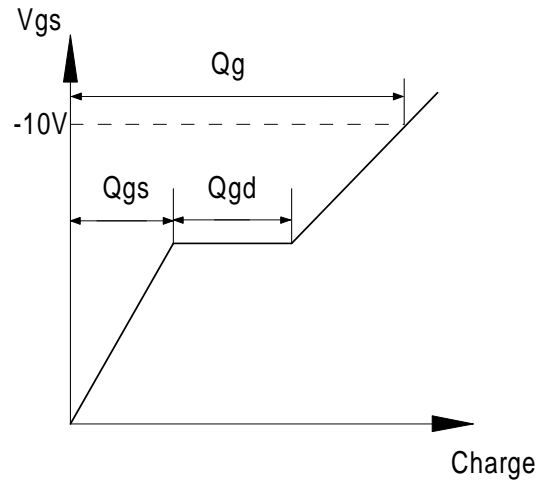
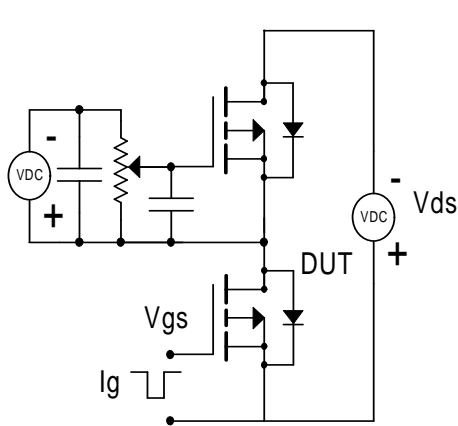

Figure 11: Normalized Maximum Transient Thermal Impedance

LOW VOLTAGE MOSFET (P-CHANNEL)

Gate Charge Test Circuit & Waveform



Resistive Switching Test Circuit & Waveforms

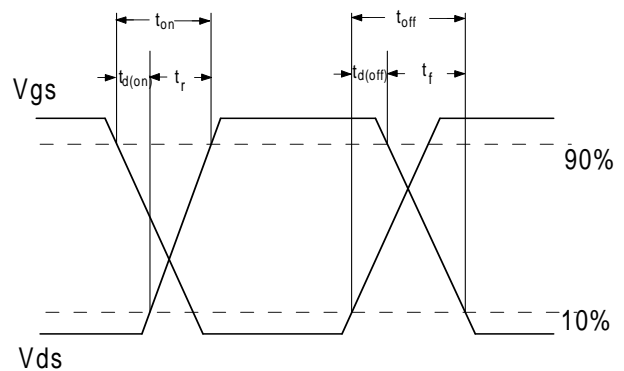
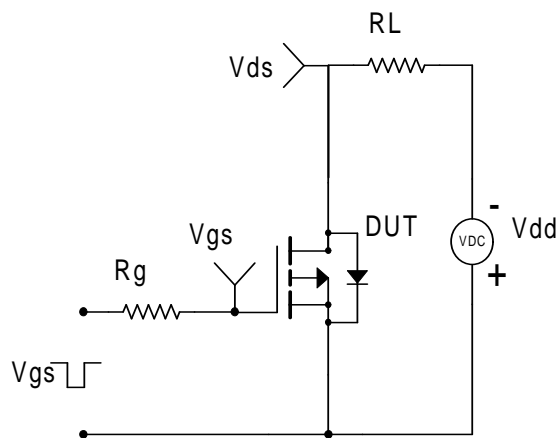

Diode Recovery Test Circuit & Waveforms

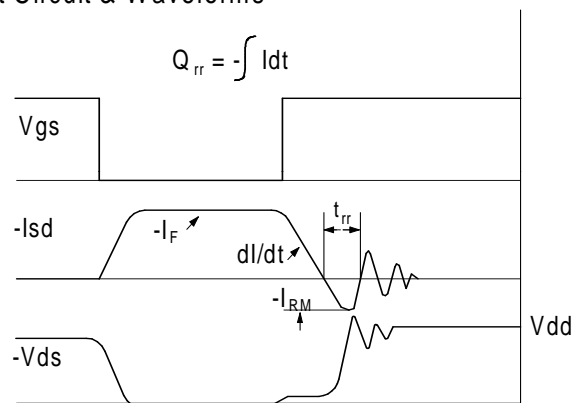
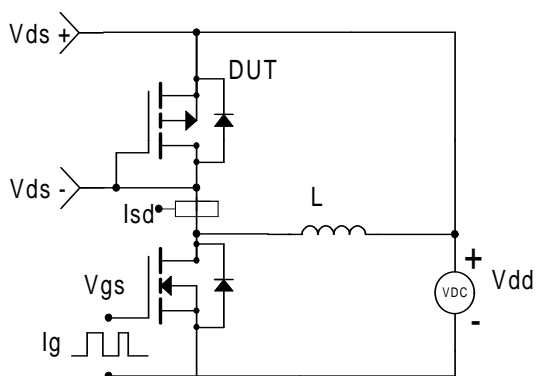

LOW VOLTAGE MOSFET (P-CHANNEL)

SOT-23 Package Outline Dimensions

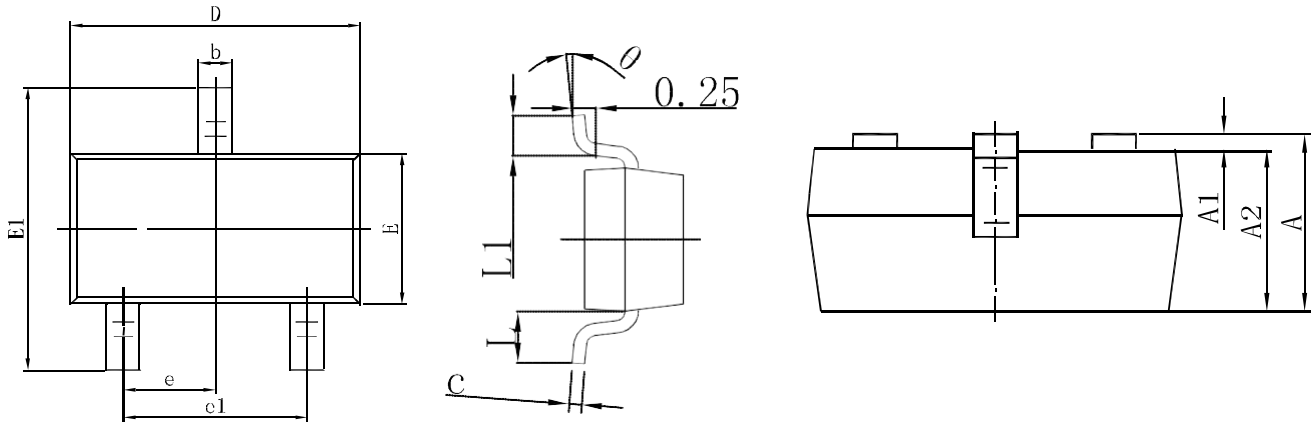

| Symbol | Dimensions In Millimeters | | Dimensions In Inches | |
|--------|---------------------------|-------|----------------------|-------|
| | Min. | Max. | Min. | Max. |
| A | 0.900 | 1.150 | 0.035 | 0.045 |
| A1 | 0.000 | 0.100 | 0.000 | 0.004 |
| A2 | 0.900 | 1.050 | 0.035 | 0.041 |
| b | 0.300 | 0.500 | 0.012 | 0.020 |
| c | 0.080 | 0.150 | 0.003 | 0.006 |
| D | 2.800 | 3.000 | 0.110 | 0.118 |
| E | 1.200 | 1.400 | 0.047 | 0.055 |
| E1 | 2.250 | 2.550 | 0.089 | 0.100 |
| e | 0.950 TYP | | 0.037 TYP | |
| e1 | 1.800 | 2.000 | 0.071 | 0.079 |
| L | 0.550 REF | | 0.022 REF | |
| L1 | 0.300 | 0.500 | 0.012 | 0.020 |
| θ | 0° | 8° | 0° | 8° |

SOT-23 Suggested Pad Layout

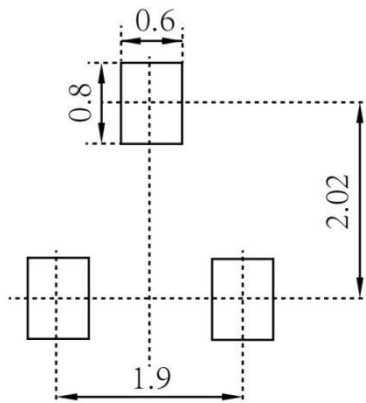

Note:

1. Controlling dimension: in millimeters
2. General tolerance: ±0.05mm
3. The pad layout is for reference purposes only

LOW VOLTAGE MOSFET (P-CHANNEL)

SOT-23 Tape and Reel

SOT-23 Embossed Carrier Tape

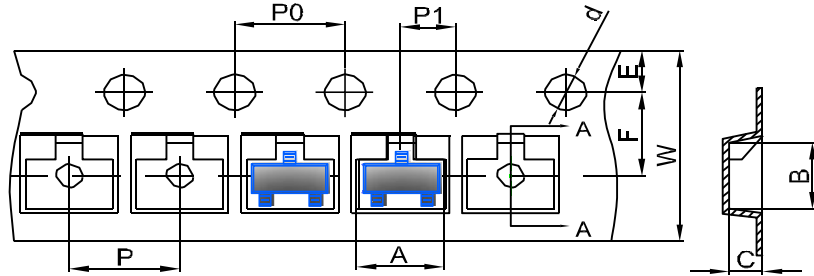

| DIMENSIONS ARE IN MILLIMETER | | | | | | | | | | |
|------------------------------|------|------|------|-------|------|------|------|------|------|------|
| TYPE | A | B | C | d | E | F | P0 | P | P1 | W |
| SOT-23 | 3.15 | 2.77 | 1.22 | Ø1.50 | 1.75 | 3.50 | 4.00 | 4.00 | 2.00 | 8.00 |
| TOLERANCE | ±0.1 | ±0.1 | ±0.1 | ±0.1 | ±0.1 | ±0.1 | ±0.1 | ±0.1 | ±0.1 | ±0.1 |

SOT-23 Tape Leader and Trailer

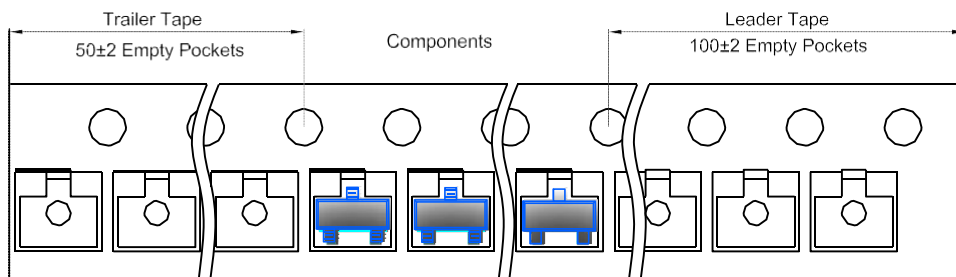

SOT-23 Reel

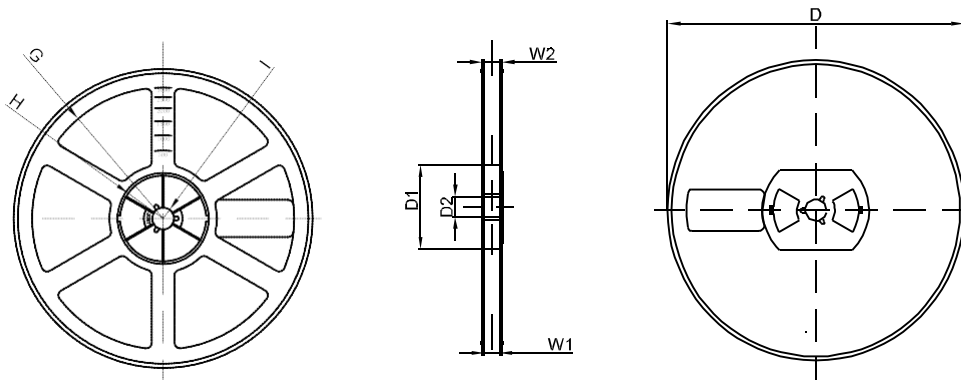

| DIMENSIONS ARE IN MILLIMETER | | | | | | | | |
|------------------------------|------|-------|-------|-----|--------|-------|------|-------|
| REEL OPTION | D | D1 | D2 | G | H | I | W1 | W2 |
| 7" DIA | Ø178 | 54.40 | 13.00 | R78 | R25.60 | R6.50 | 9.50 | 12.30 |
| TOLERANCE | ±2 | ±1 | ±1 | ±1 | ±1 | ±1 | ±1 | ±1 |