

**FEATURES**

- Glass Passivated Die Construction
- Super-Fast Recovery Time For High Efficiency
- Low Forward Voltage Drop and High Current Capability
- Ideally Suited for Automated Assembly
- Plastic Material: UL Flammability Classification Rating 94V-0



SMBF

**MECHANICAL DATA**

- Case: SMBF Molded plastic
- Terminals: Pure tin plated, lead free
- Polarity: Indicated by cathode band
- Weight: 57mg (approx.)



Cathode

**MAXIMUM RATINGS AND ELECTRICAL CHARACTERISTICS**

Ratings at 25 °C ambient temperature unless otherwise specified. Single phase, half wave, 60 Hz, resistive or inductive load. For capacitive load, derate current by 20%.

Parameter	Symbol	ES5ABF	ES5BBF	ES5DBF	ES5GBF	ES5JBF	Unit
Maximum Repetitive Peak Reverse Voltage	$V_{RRM}$	50	100	200	400	600	V
Maximum RMS Voltage	$V_{RMS}$	35	70	140	280	420	V
Maximum DC Blocking Voltage	$V_{DC}$	50	100	200	400	600	V
Maximum Average Forward Rectified Current at $T_A=75\text{ °C}$	$I_{F(AV)}$	5.0					A
Peak Forward Surge Current 8.3ms Single Half Sine-wave Superimposed on Rated Load (JEDEC)	$I_{FSM}$	150			135		A
Maximum Instantaneous Forward Voltage at 5 A	$V_F$	1.0			1.25	1.7	V
Maximum DC Reverse Current at Rated DC Blocking Voltage	$I_R$	$T_A = 25\text{ °C}$		10.0			$\mu\text{A}$
		$T_A = 100\text{ °C}$		100.0			
Maximum reverse recovery time (NOTE1)	$t_{rr}$	35					nS
Typical Junction Capacitance (NOTE2)	$C_J$	95					pF
Maximum Thermal Resistance (NOTE3)	$R_{\theta JL}$	45					$^{\circ}\text{C/W}$
Operating and Storage Temperature Range	$T_{J, TS}$	- 50 to + 150					$^{\circ}\text{C}$

Note: 1.Reverse recovery condition  $I_F=0.5\text{A}, I_R=1.0\text{A}, I_{rr}=0.25\text{A}$

2.Measured at 1MHz and applied reverse voltage of 4.0V D.C.

3.P.C.B. mounted with 0.2x0.2"(5.0x5.0mm) copper pad areas

**Fig.1 Reverse Recovery Time Characteristic And Test Circuit Diagram**

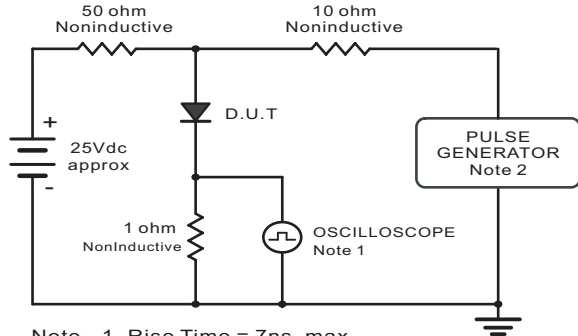

Note: 1. Rise Time = 7ns, max.  
Input Impedance = 1megohm, 22pF.  
2. Rises Time = 10ns, max.  
Source Impedance = 50 ohms.

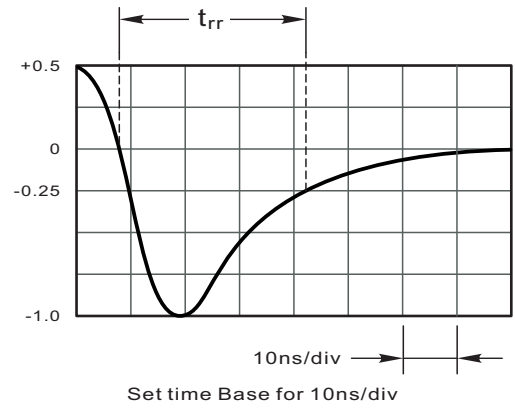

**Fig.2 Maximum Average Forward Current Rating**

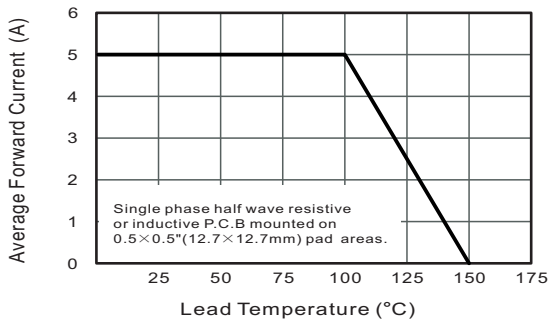

**Fig.3 Typical Reverse Characteristics**

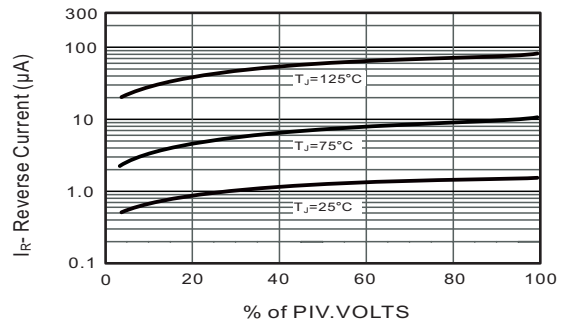

**Fig.4 Typical Forward Characteristics**

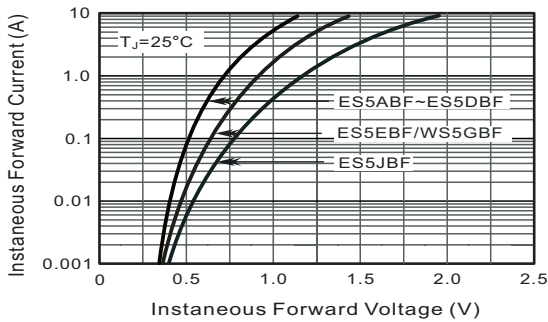

**Fig.5 Typical Junction Capacitance**

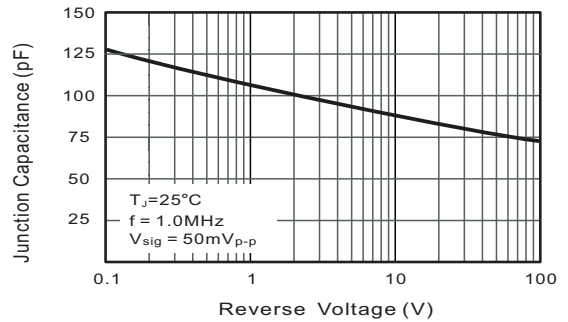

**Fig.6 Maximum Non-Repetitive Peak Forward Surge Current**

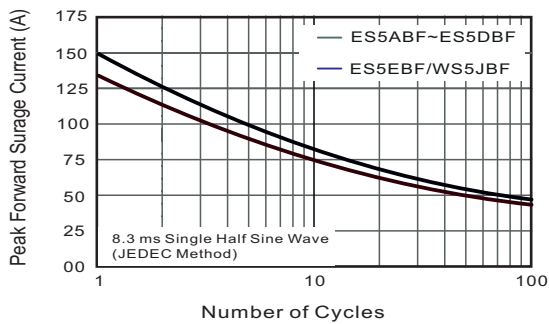

**SMBF Package Outline Dimensions**

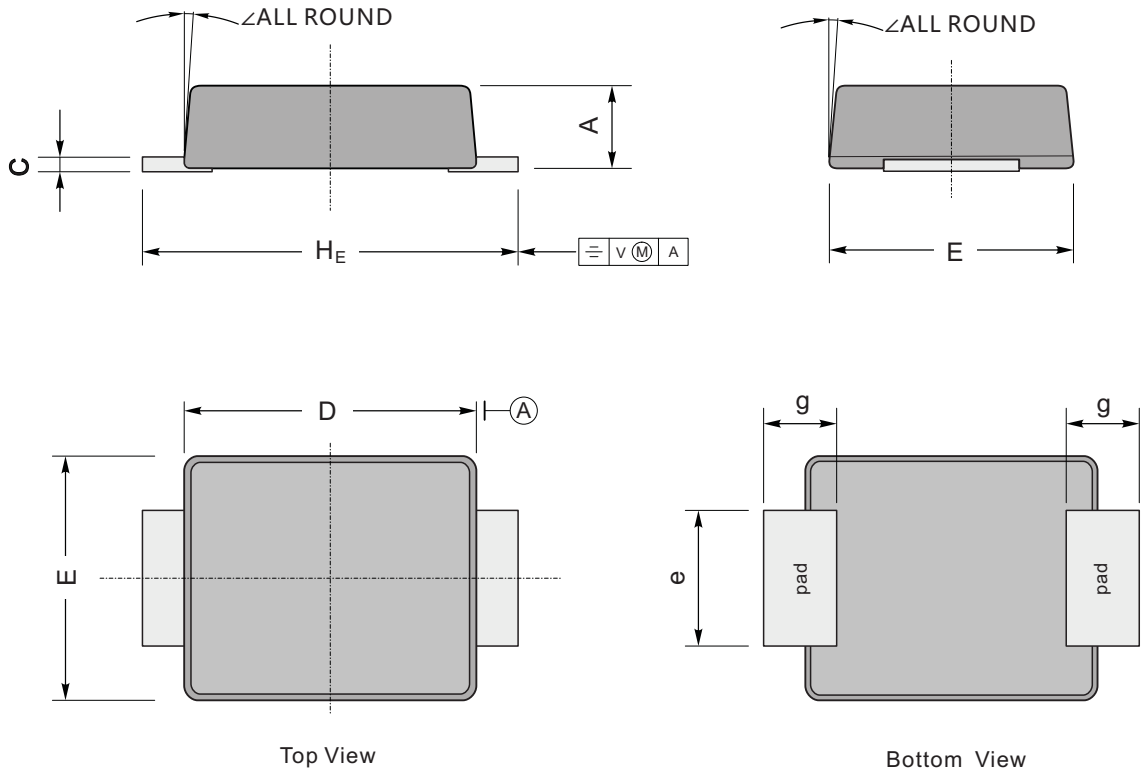

UNIT		A	C	D	E	$H_E$	e	g	$\angle$
mm	max	1.3	0.26	4.4	3.7	5.5	2.2	1.0	$9^\circ$
	min	1.1	0.18	4.2	3.5	5.1	1.9		
mil	max	51	10	173	146	216	86	40	
	min	43	7	165	138	200	75		