

## 650V N-Channel Power MOSFET

### Features

- $V_{DS}:650V, I_D:7A, R_{DS(ON)} < 1.5\Omega @ V_{GS}=10V$
- Fast switching capability
- Low gate charge
- Lead free in compliance with EU RoHS directive.
- Green molding compound

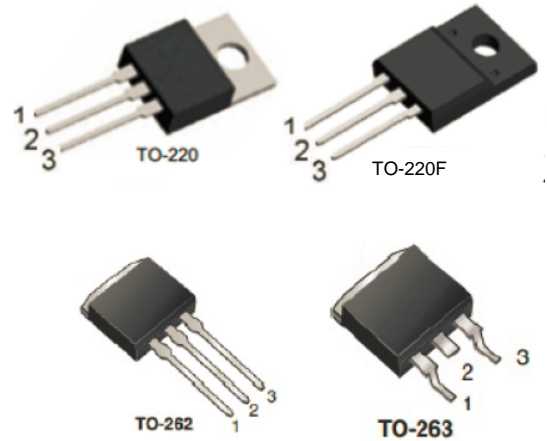

### Ordering Information

Part No.	Package	Packing
HKTF7N65-TU	TO-220	50pcs / Tube
HKTF7N65F-TU	TO-220F	50pcs / Tube
HKTY7N65-TU	TO-262	50pcs / Tube
HKTE7N65-TU	TO-263	50pcs / Tube
HKTE7N65-TR	TO-263	800pcs / 13" Reel

### Block Diagram

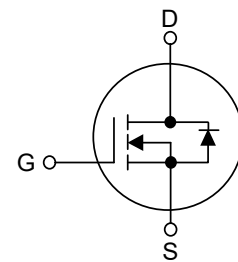

### ABSOLUTE MAXIMUM RATINGS ( $T_C=25^\circ C$ , unless otherwise specified)

PARAMETER		SYMBOL	RATINGS	UNIT
Drain-Source Voltage		$V_{DSS}$	650	V
Gate-Source Voltage		$V_{GSS}$	$\pm 30$	V
Continuous Drain Current		$I_D$	7	A
Pulsed Drain Current (Note 2)		$I_{DM}$	28	A
Avalanche Energy	Single Pulsed (Note 3)	$E_{AS}$	435	mJ
Power Dissipation	TO-220/TO-262/TO-263	$P_D$	142	W
	TO-220F		48	W
Junction Temperature		$T_J$	+150	$^\circ C$
Storage Temperature		$T_{STG}$	-55 ~ +150	$^\circ C$

Notes: 1. Absolute maximum ratings are those values beyond which the device could be permanently damaged.

Absolute maximum ratings are stress ratings only and functional device operation is not implied.

2. Repetitive Rating : Pulse width limited by  $T_J$

3.  $L = 30mH, I_{AS} = 5.25A, V_{DD} = 50V, R_G = 25 \Omega$ , Starting  $T_J = 25^\circ C$

**650V N-Channel Power MOSFET**

PARAMETER		SYMBOL	RATING	UNIT
Junction to Ambient	TO-220/TO-220F TO-262/TO-263	$\theta_{JA}$	62.5	$^{\circ}\text{C/W}$
Junction to Case	TO-220/TO-262/TO-263	$\theta_{JC}$	0.90	$^{\circ}\text{C/W}$
	TO-220F		2.6	

**ELECTRICAL CHARACTERISTICS** ( $T_C=25^{\circ}\text{C}$ , unless otherwise specified)

PARAMETER		SYMBOL	TEST CONDITIONS	MIN	TYP	MAX	UNIT
<b>OFF CHARACTERISTICS</b>							
Drain-Source Breakdown Voltage		$BV_{DSS}$	$V_{GS}=0V, I_D=250\mu A$	650			V
Drain-Source Leakage Current		$I_{DSS}$	$V_{DS}=650V, V_{GS}=0V$			1	$\mu A$
Gate- Source Leakage Current	Forward	$I_{GSS}$	$V_{GS}=30V, V_{DS}=0V$			100	nA
	Reverse		$V_{GS}=-30V, V_{DS}=0V$			-100	nA
Breakdown Voltage Temperature Coefficient		$\Delta BV_{DSS}/\Delta T_J$	$I_D=250\mu A$ , Referenced to $25^{\circ}\text{C}$		0.67		$V/^{\circ}\text{C}$
<b>ON CHARACTERISTICS</b>							
Gate Threshold Voltage		$V_{GS(TH)}$	$V_{DS}=V_{GS}, I_D=250\mu A$	2.0		4.0	V
Static Drain-Source On-State Resistance		$R_{DS(ON)}$	$V_{GS}=10V, I_D=3.5A$		1.35	1.5	$\Omega$
<b>DYNAMIC CHARACTERISTICS</b>							
Input Capacitance		$C_{ISS}$	$V_{DS}=25V, V_{GS}=0V, f=1.0\text{ MHz}$		1210	1400	pF
Output Capacitance		$C_{OSS}$			140	180	pF
Reverse Transfer Capacitance		$C_{RSS}$			40	50	pF
<b>SWITCHING CHARACTERISTICS</b>							
Turn-On Delay Time		$t_{D(ON)}$	$V_{DD}=300V, I_D=7A,$ $R_G=25\Omega$ (Note 1, 2)		50	70	ns
Turn-On Rise Time		$t_R$			150	180	ns
Turn-Off Delay Time		$t_{D(OFF)}$			380	410	ns
Turn-Off Fall Time		$t_F$			180	220	ns
Total Gate Charge		$Q_G$	$V_{DS}=520V, I_D=7A,$ $V_{GS}=10V$ (Note 1, 2)		29	38	nC
Gate-Source Charge		$Q_{GS}$			9		nC
Gate-Drain Charge		$Q_{GD}$			19		nC
<b>DRAIN-SOURCE DIODE CHARACTERISTICS AND MAXIMUM RATINGS</b>							
Drain-Source Diode Forward Voltage		$V_{SD}$	$V_{GS}=0V, I_S=7A$			1.4	V
Maximum Continuous Drain-Source Diode Forward Current		$I_S$				7	A
Maximum Pulsed Drain-Source Diode Forward Current		$I_{SM}$				28	A
Reverse Recovery Time		$t_{rr}$	$V_{GS}=0V, I_S=7.0A,$		490		ns
Reverse Recovery Charge		$Q_{RR}$	$di/dt=100\text{ A}/\mu\text{s}$ (Note 1)		3.2		$\mu\text{C}$

 Notes: 1. Pulse Test: Pulse width  $\leq 300\mu\text{s}$ , Duty cycle  $\leq 2\%$ .

2. Essentially independent of operating temperature.

**650V N-Channel Power MOSFET**

**TEST CIRCUITS AND WAVEFORMS**

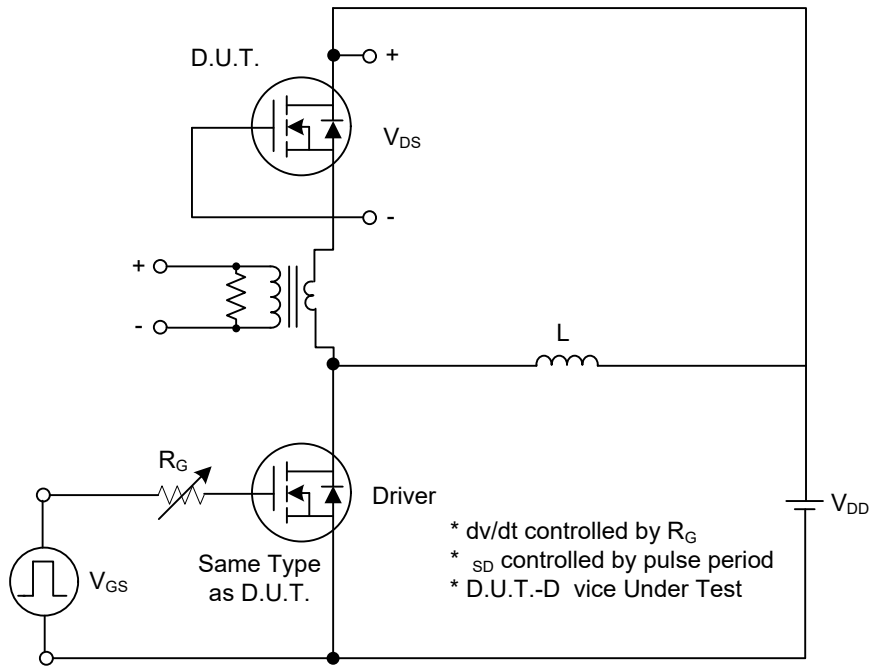

**Peak Diode Recovery  $dv/dt$  Test Circuit**

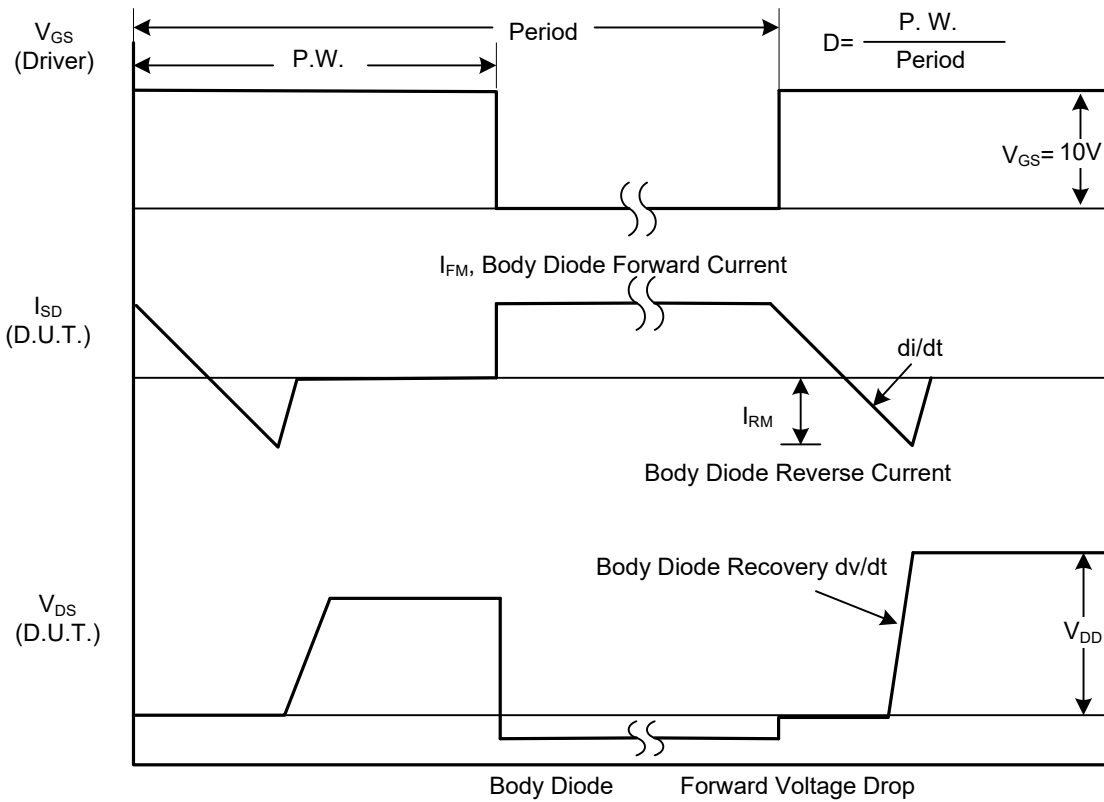

**Peak Diode Recovery  $dv/dt$  Waveforms**

**650V N-Channel Power MOSFET**

**TEST CIRCUITS AND WAVEFORMS(Cont.)**

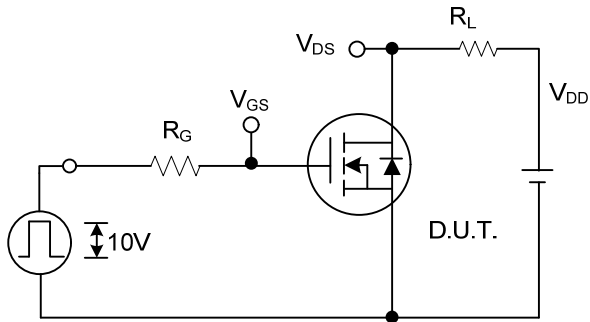

**Switching Test Circuit**

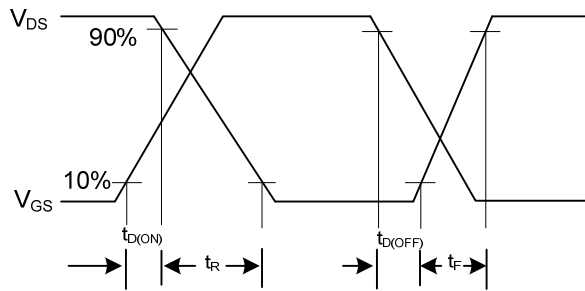

**Switching Waveforms**

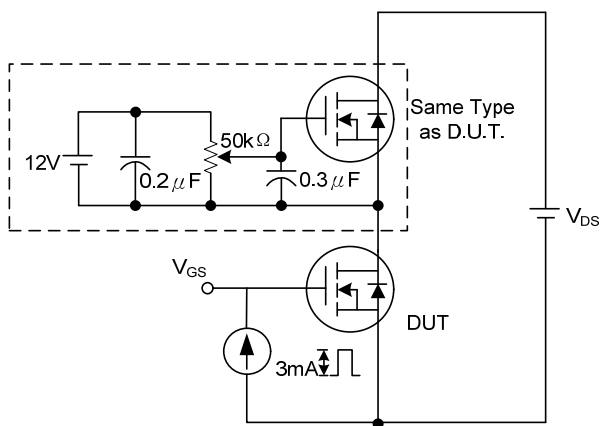

**Gate Charge Test Circuit**

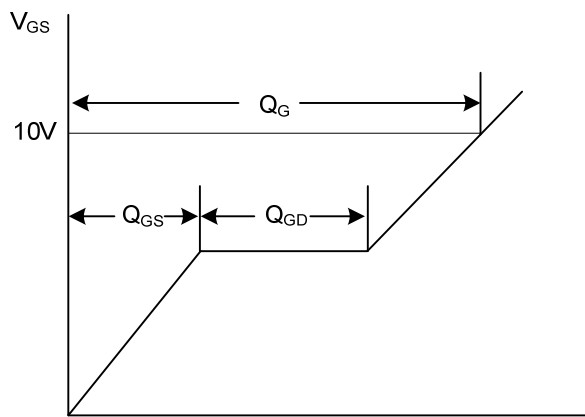

**Gate Charge Waveform**

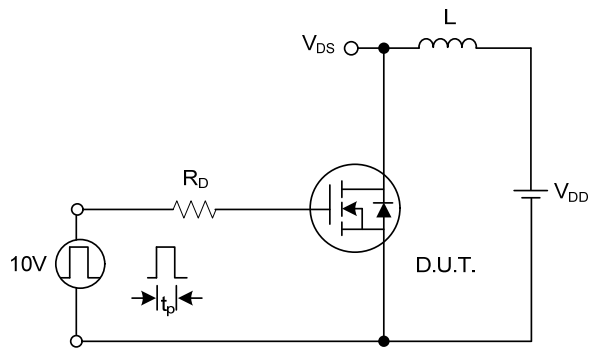

**Unclamped Inductive Switching Test Circuit**

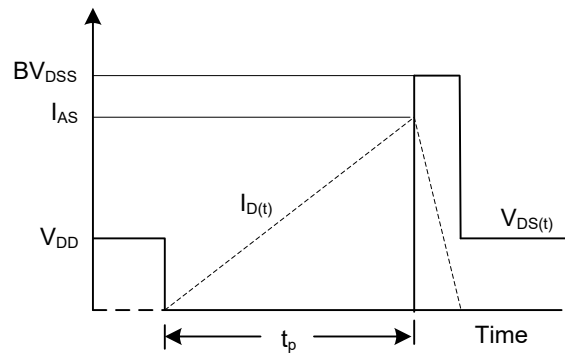

**Unclamped Inductive Switching Waveforms**

**650V N-Channel Power MOSFET**

**TYPICAL CHARACTERISTICS**

On-State Characteristics

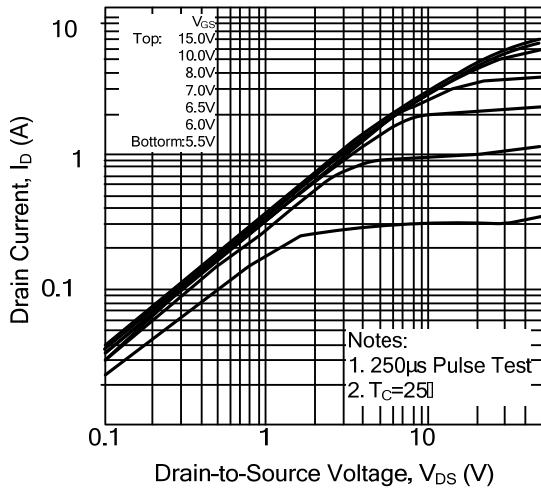

Transfer Characteristics

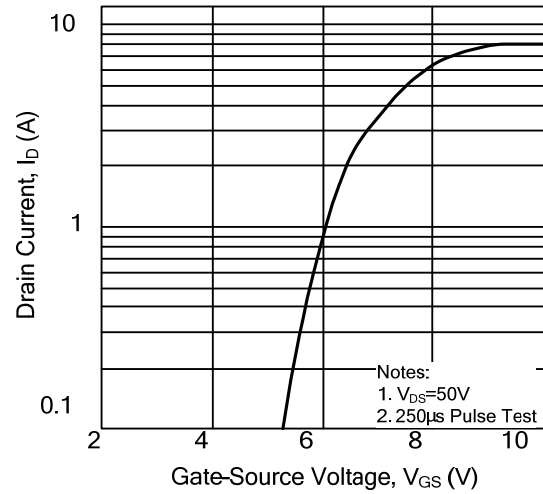

On-Resistance Variation vs. Drain Current and Gate Voltage

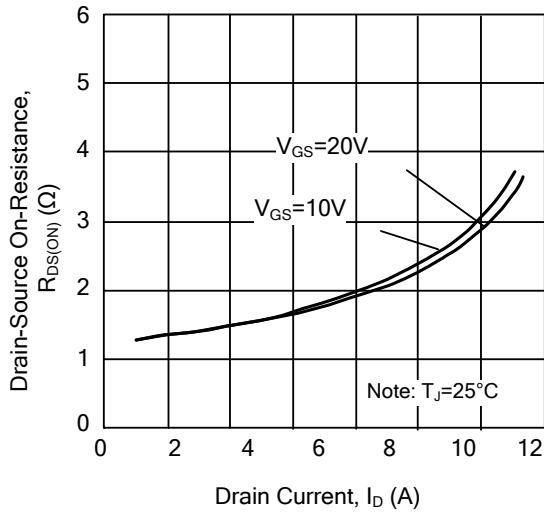

On State Current vs. Allowable Case Temperature

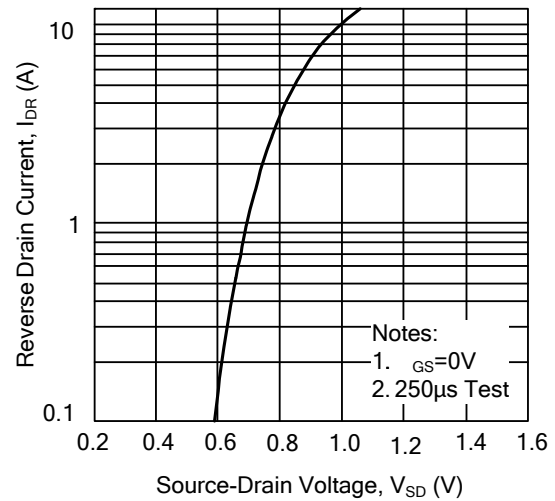

Capacitance Characteristics (Non-Repetitive)

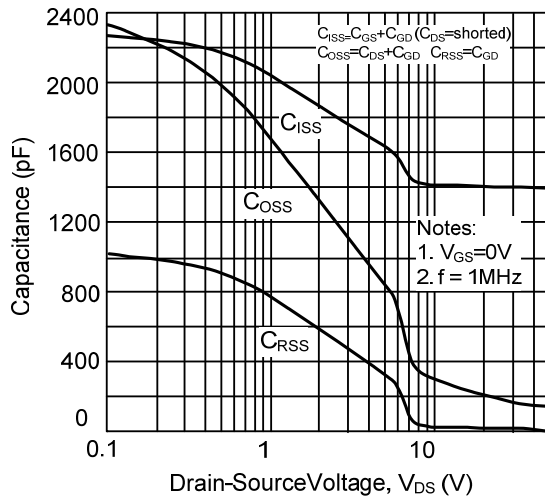

Gate Charge Characteristics

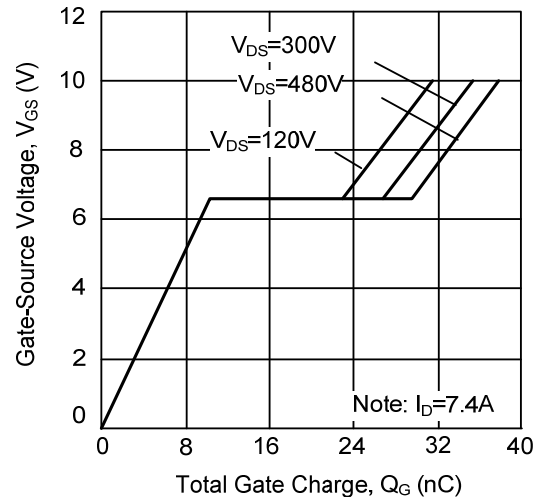

**650V N-Channel Power MOSFET**

**TYPICAL CHARACTERISTICS**

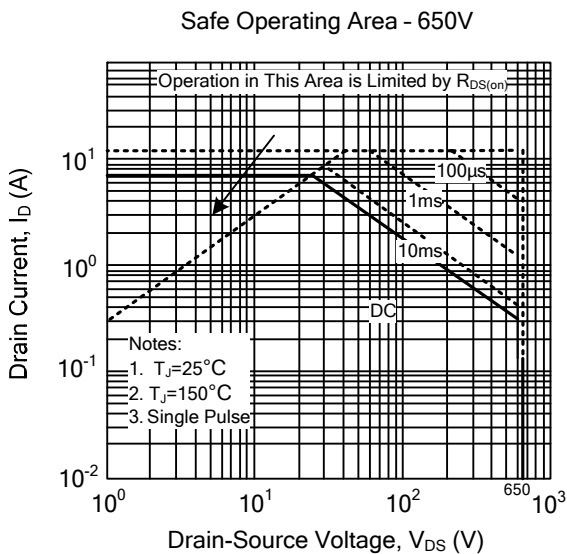
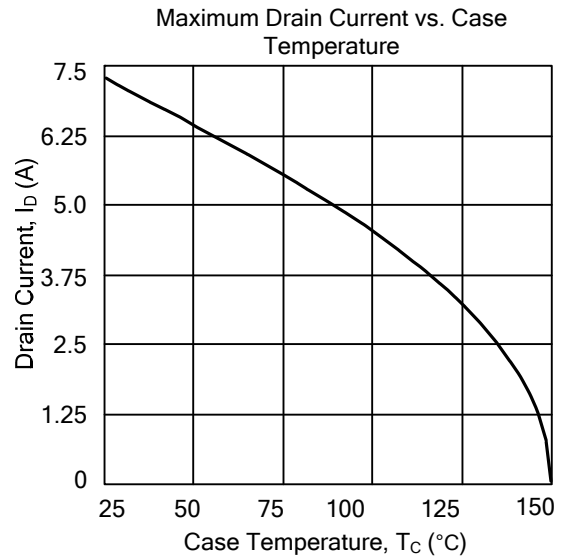
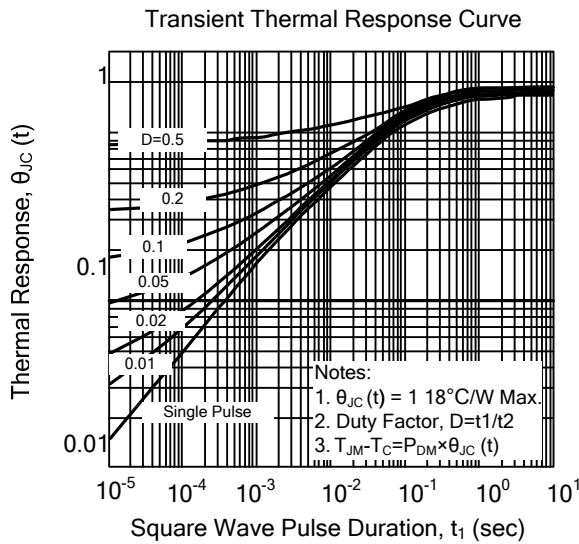
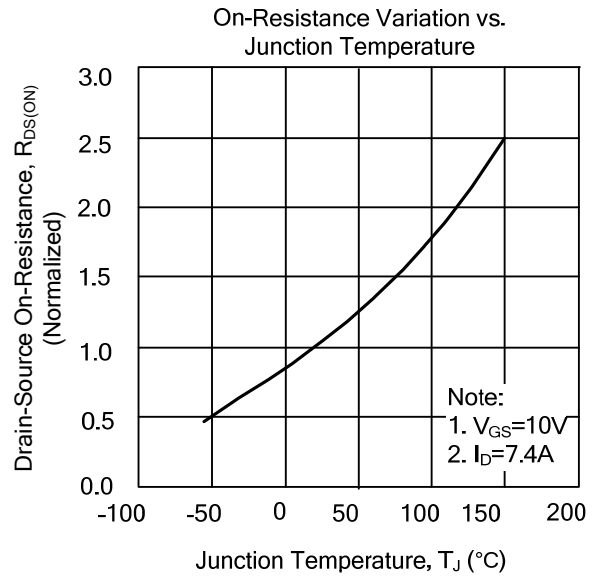
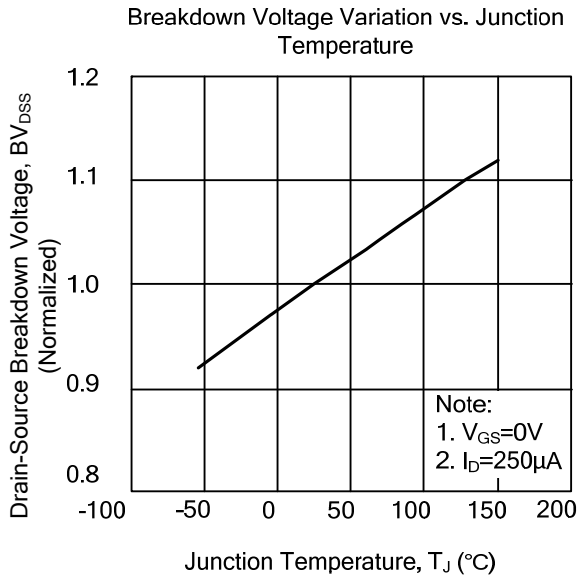

### TO-220 Mechanical Drawing

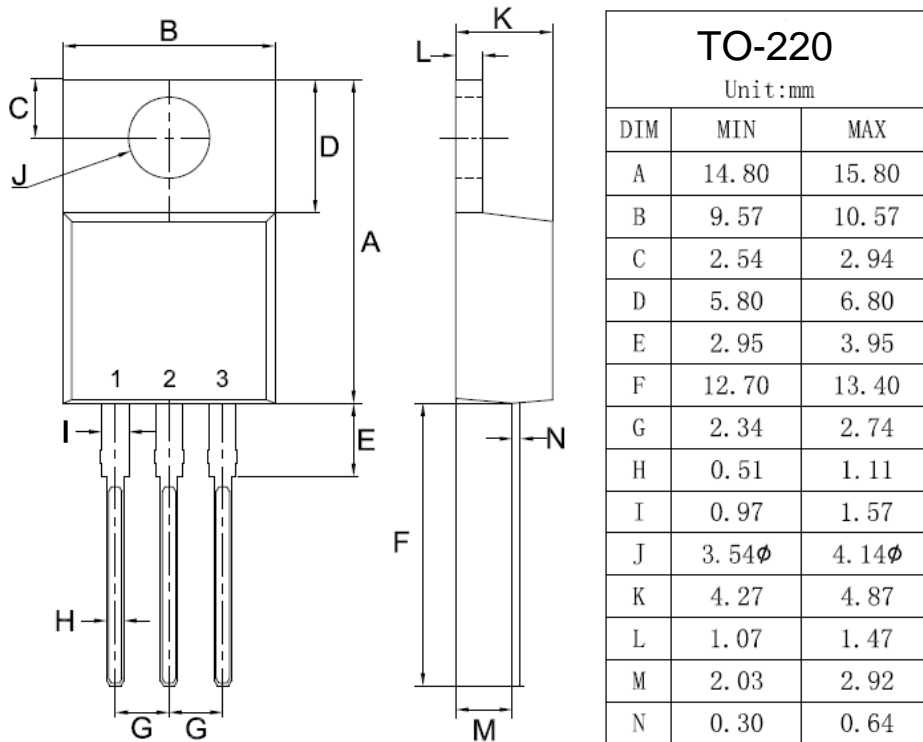

### TO-220F Mechanical Drawing

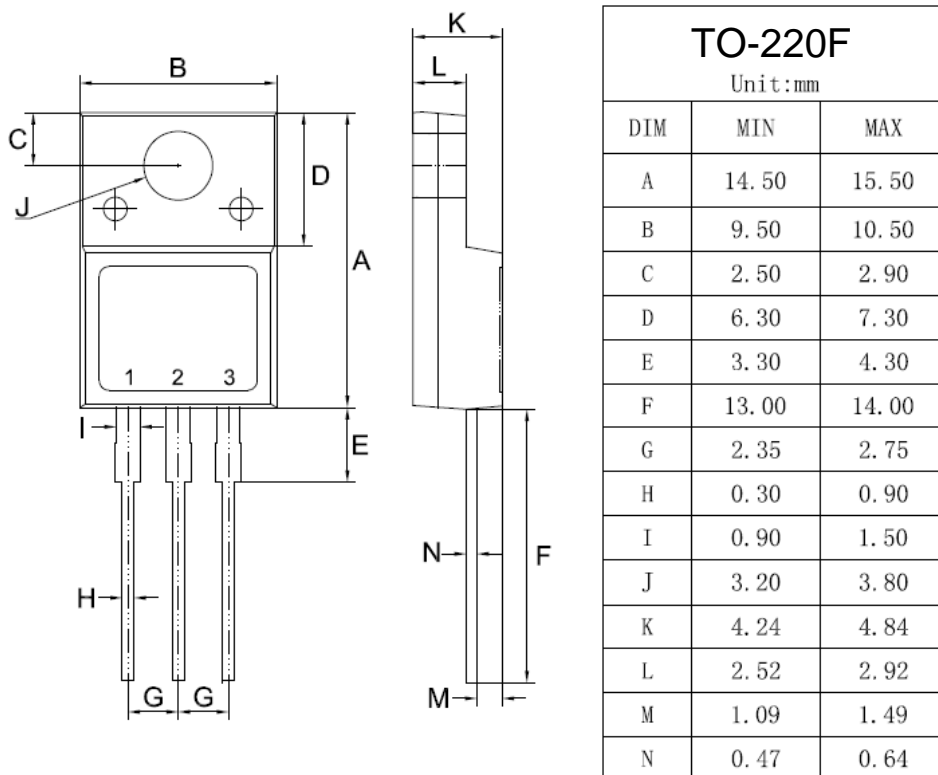

**TO-262 Mechanical Drawing**

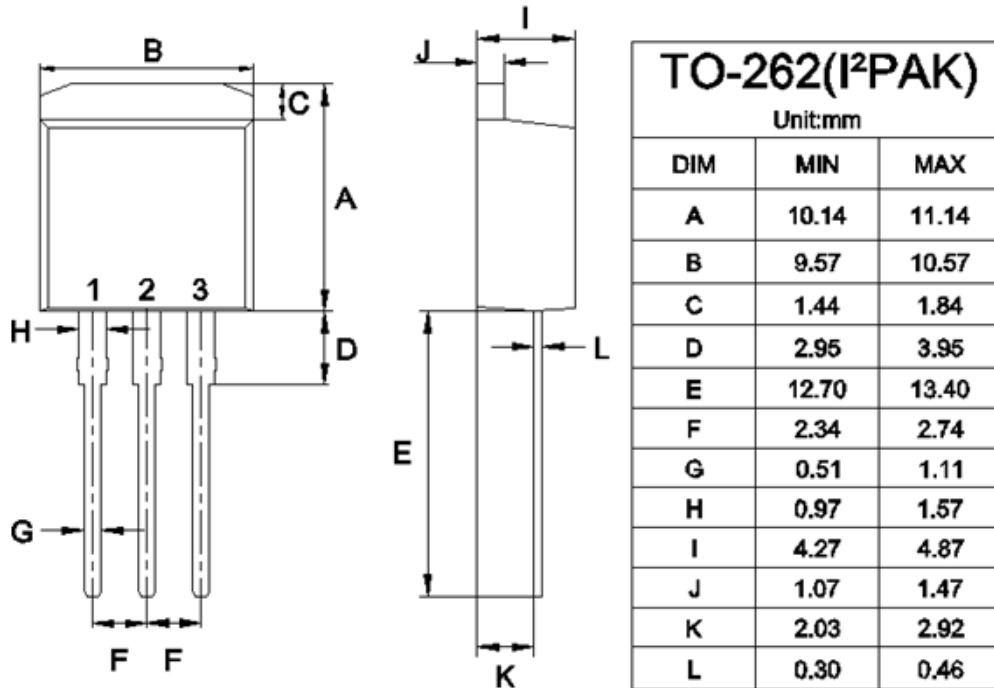

**TO-263 Mechanical Drawing**

